

SONOPULS

Ultrasonic homogenisers

Instructions for the use and applications

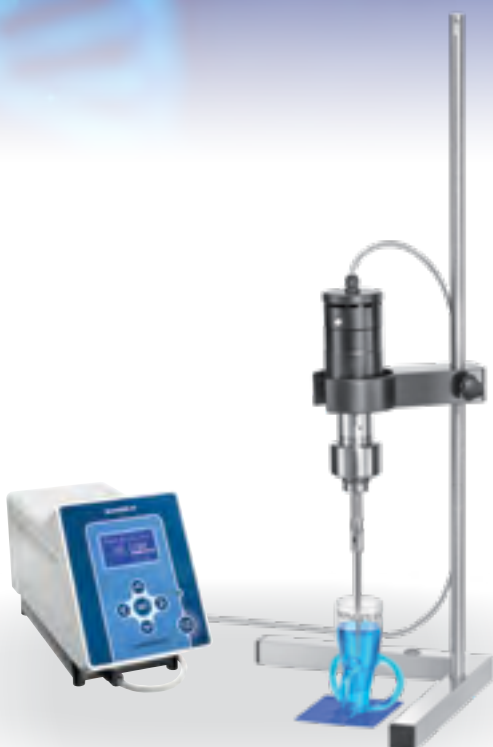
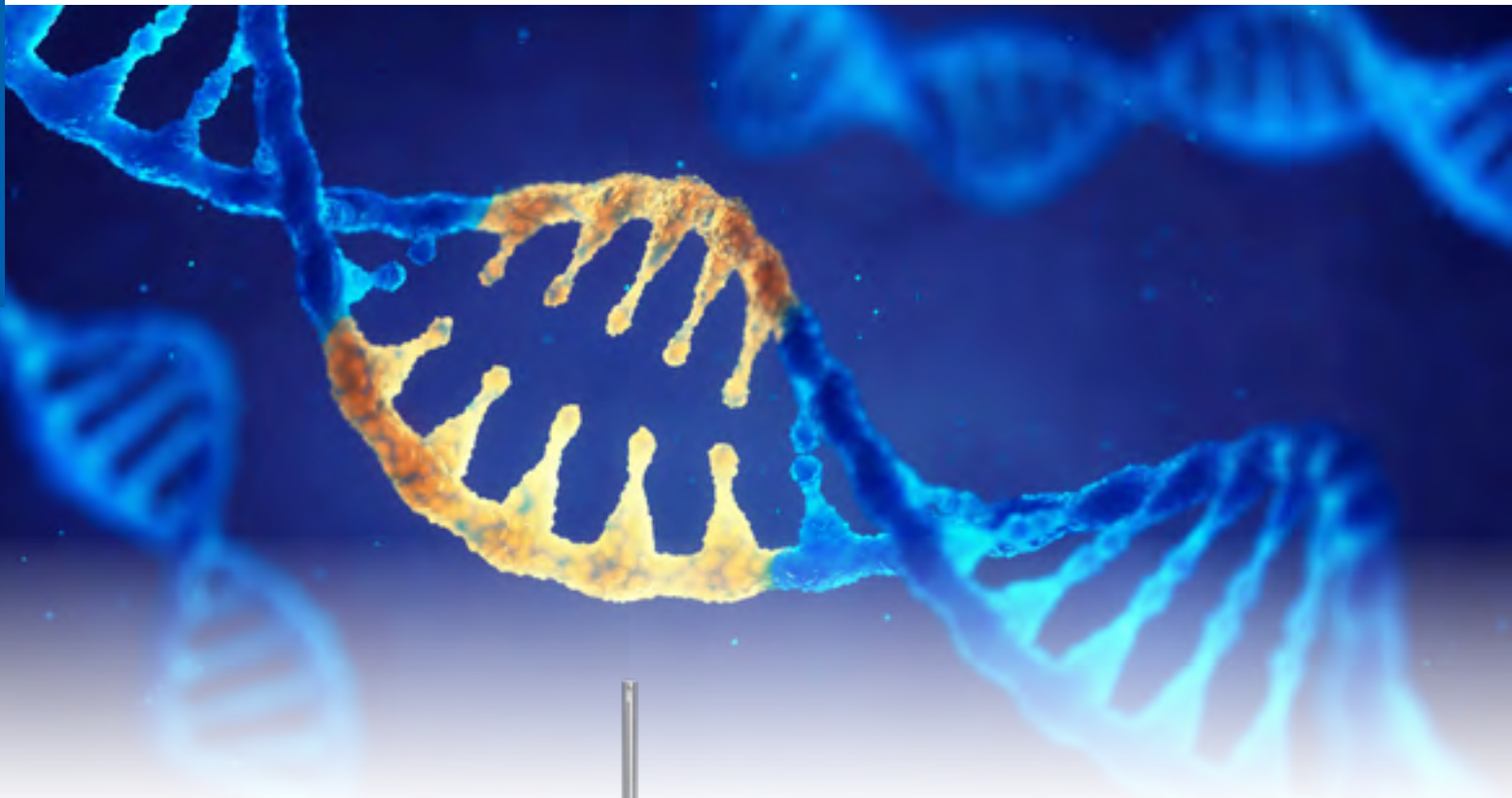

- Homogenising
- Extracting
- Suspending
- Disagglomerating
- Degassing
- Emulsifying
- Disrupting cells and tissue
- Optimising processes
- Accelerating chemical reactions

1964



Production of the first ultrasonic homogenisers
with tube technology
SONOREX HE 1

1986



Product launch of
ultrasonic homogenisers **SD 9**

Content

1	Introduction.....	2
2	Quick start for use of the device in laboratories.....	3
3	Basic principles	4
4	Devices and application parameters.....	5
4.1	Basic structure of an ultrasonic homogeniser.....	5
4.2	Important characteristics of SONOPULS ultrasonic homogenisers.....	6
4.3	Choosing a device	8
4.4	Selection of method parameters	18
4.5	Setting the sonication parameters.....	20
5	Overview of applications.....	21
5.1	Basic procedures	21
5.2	Branches with ultrasonic applications	24
6	Detailed applications	27
6.1	Classification based on process	28
6.2	Classification by branches / working areas	32
6.3	Publications.....	37
7	FAQs.....	38
7.1	FAQs concerning practical application.....	38
7.2	FAQs concerning devices, probes and safety aspects	38
7.3	FAQs concerning standards and guidelines.....	39
8	A final word	39
	Company portrait	40

1991

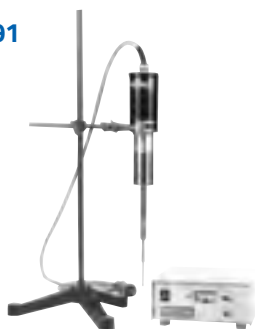

Ultrasonic homogenisers
SONOPULS HD

2020



Ultrasonic homogenisers
SONOPULS series 4000

1 Introduction

Welcome to the third edition of the application guide for the SONOPULS ultrasonic homogeniser. Perhaps you are interested in its wide range of application options before purchasing or have just acquired the device and are now introducing it as the routine method for individual applications or several applications at the same time. Or maybe you have already been using the ultrasonic homogenising method for a specific application for a long time, and have now discovered how diversely it can be employed for further applications in your working environment.

On the following pages you can find a wealth of information for a wide range of fields and different purposes. And that is precisely our aim.

The application guide has been produced in response to our customers' suggestions and for the benefit of our existing and potential customers. And not only that: it has also been compiled in cooperation **with** our customers. Users report on their practical experiences and make available the method parameters that they have employed successfully. Last but not least, this third edition includes the experiences and knowledge collected in our ultrasound application seminars, in which we delved into the world of ultrasonics with theory and practice reports. The discussions and practical applications using the participants' samples resulted in an array of new experiences for the successful application of the devices. How can the devices be used successfully, how can they be optimally integrated into existing processes and what product features and information are important to users?

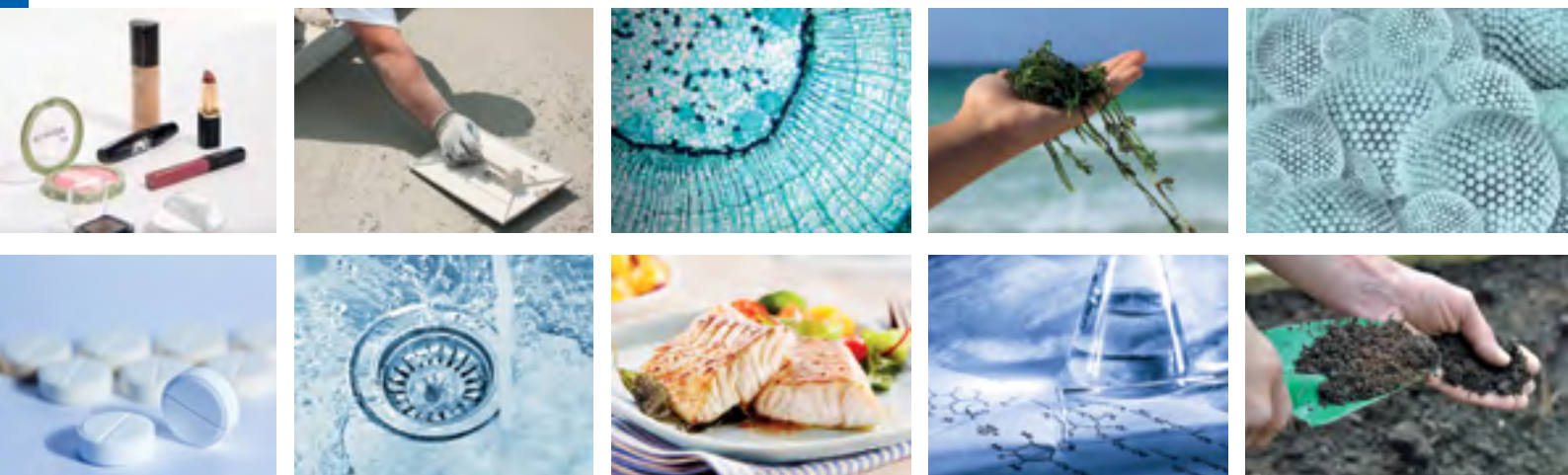

The ultrasonic homogeniser's method, in other words the direct application of ultrasonic power to the sample, has proven its worth as a complement to the old, familiar, laboratory ultrasonic baths, which have proven themselves in practice for decades. Foodstuffs, soil, waste, nanoparticles, materials, cosmetics, pharmaceuticals, biotechnology, microbiology, life sciences and chemistry are just some of the fields in which the ultrasonic homogeniser, manufactured by BANDELIN since 1964, is already in use.

Whenever the task involves

- homogenising, suspending, emulsifying,
- sample preparation for analysis,
- disagglomerating, extracting,
- cell and tissue disruption or
- sonochemistry,

the use of the ultrasonic homogeniser is of interest as long as a liquid medium is available.

2 Quick start for use of the device in laboratories

The following pages address a range of topics in detail with the aim of communicating a solid understanding of the methods themselves and their very diverse range of application possibilities. Below you will find the most important steps for a very quick start with the SONOPULS:

For which applications are actually possible with the ultrasonic homogeniser, please see chapter 5 onwards.

1. Structure

- a. See instructions for use

2. Selection of correct probe for respective application

- a. Already selected during sales consultation
- b. or see from chap. 4.3.3.

3. Selection of vessel

- a. When the device and probe are selected appropriately, you can generally use the vessels of your choice, for example ones which are suitable for the activities before and / or after sonication.
- b. Narrow, taller vessels are basically more suitable than wider, shallower vessels with the same volumes.
- c. The vessel should not be filled more than 2/3 with liquid (risk of splashing).
- d. If needed, further details can be found from chap. 4.3.3.

4. For further information on the application, tips and tricks, see chap. 4.4.

5. For an explanation of how to select sonication parameters, see chap. 4.5.

6. Overview of specific applications with information on all details of application, see chap. 6 onwards.

7. Do you already use our new **sound proof box LS 40** for considerable noise reduction during application? Find out more on our website at www.sonopuls.info or contact us directly!



3 Basic principles

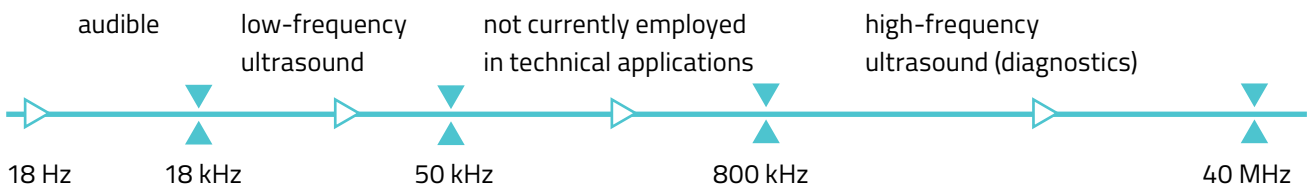

What is ultrasound and how does it work?

Oscillations with frequencies above 18 kHz (18,000 oscillations per second) are referred to as ultrasound. Low-frequency ultrasound is used in laboratories whilst a higher frequency range is used for medical diagnostics.

The low-frequency ultrasonic oscillations result in the generation of millions of tiny vacuum bubbles in all liquids, which then implode immediately generating highly effective pressure surges. This process is called cavitation. Low frequencies of around 20 kHz create bubbles with larger diameters and more intensive pressure surges than compared with frequencies of around 35 kHz. Low-frequency ultrasound has been used in a wide range of ultrasound baths for decades. The cavitation process effectively and gently removes residual dirt from the surfaces of components immersed in the fluid as well as out of recesses and holes.

Other applications include the degassing and mixing of liquids.

Ultrasonic baths versus ultrasonic homogenisers

Compared with the very widely employed ultrasonic baths, ultrasonic homogenisers can be used to apply a considerably higher power density in the liquid. The ultrasound power is released into the liquid via the tip (probe). The oscillations of the probe create at the tip the millions of minute vacuum bubbles described previously, which implode very quickly and trigger shockwaves above 1,000 bar, which can cause detachment of particles or mixing of solution components.

The following table illustrates more clearly the differences between ultrasonic baths and homogenisers.

	Ultrasonic bath	Ultrasonic homogeniser
Sample volumes	approx. 10 – 500 ml	starting at 0.5 µl – 3 l (stationary)
Amplitude [µm]	approx. 4	max. 300 (peak to peak)
Intensity [W/l]	up to 50	up to 3,000
Frequency [kHz]	35 industry: 25 or 40	20 (30 / 40)
Sonic distribution	broad	focused
Contamination due to cavitation erosion	insignificant, as sonication is usually indirect	yes, low wear of probe tip in direct sonication, traces of minute titanium particles (TiAl6V4) observed in sample

4 Devices and application parameters

Ultrasonic homogenisers are employed for a wide range of tasks in laboratories every day and the variety of devices on offer is just as varied. A sound understanding of the basic structure of the homogenisers and the resulting application-specific selection of the individual components forms the basis for a successful application.

<https://www.youtube.com/watch?v=ykvS2gldQnw>



4.1 Basic structure of an ultrasonic homogeniser

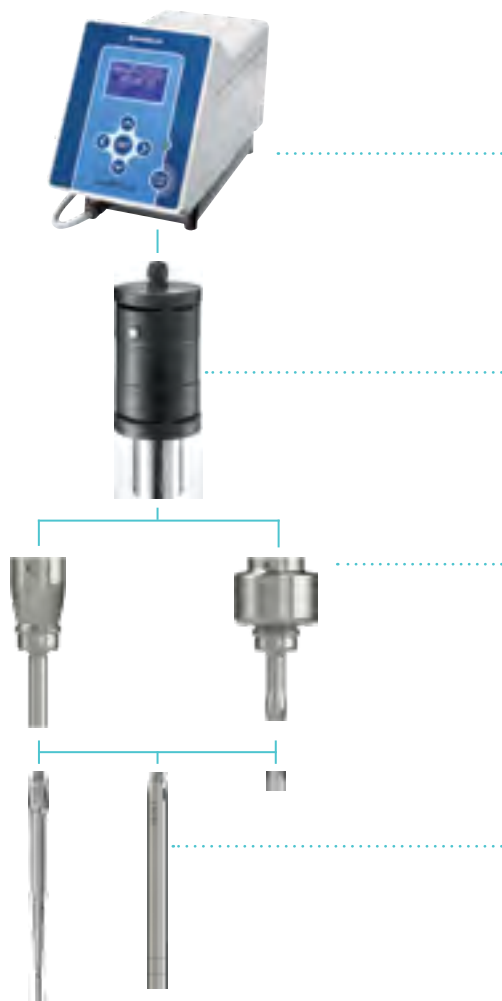

Structure and function

Ultrasonic generator (control module)

Conversion of inputted low-frequency mains energy of 50/60 Hz into high-frequency voltage of 20 kHz. Control and display of all process parameters and workflows.

Ultrasonic converter

Conversion of the electrical voltage supplied by the generator into mechanical oscillations in the same frequency.

Stepped and booster horns

They intensify the oscillations emitted by the ultrasonic converter. The degree of intensification of the amplitude depends on the design.

Probes

They transmit the mechanical oscillations to the sample. The oscillations are only emitted from the tip, not the sides. A high amplitude means particularly intensive sonication. The design of some probes allows them to generate multiple amplitude intensifications. Consequently, the probes attain the highest ultrasonic power densities in liquids.

4.2 Important characteristics of SONOPULS ultrasonic homogenisers

Understanding of the terms power and amplitude

The electrical power rating [W] is not the only decisive factor in the selection of an ultrasonic homogeniser.

This value specifies the **power consumption** of the ultrasonic generator, **but not the power applied to the sample**. The **amplitude** (up and down movements) of the probe in relation to the sample quantity is decisive for the efficiency and reproducibility of the sonication result. Compared with devices available on the market as standard, SONOPULS ultrasonic homogenisers deliver **higher probe amplitudes with the same electrical power consumption**.

Amplitude and intensity have a direct relationship; a low amplitude delivers a low intensity of sonication. For reproducible results, all parameters like amplitude setting, temperature, viscosity and volume of the sample need to remain constant. The amplitude and not the power of the generator, is the sole criterion to reproduce sonication results. But, generator power has a variable relationship with the amplitude/intensity:

When sonicating a highly viscous sample, more power is required than when sonicating water.

What does that mean?

The higher the viscosity of the medium to be sonicated, the more power is required to reach the same amplitude. It can be compared with the speed of a car: Objective: 40 km/h (= amplitude) – more power is required to maintain this speed when driving uphill.

The AMPLICHRON procedure developed by BANDELIN guarantees a **constant amplitude**, independent of changing conditions in the sample to be sonicated and helps you achieve reproducible results. The relative amplitude in per cent is specified for BANDELIN devices and shown on the display. If the actual value for the amplitude does not conform with the set value, e.g., due to probe wear (see chap. 4.4.2) or the viscosity of the medium being too high, this is easily identified and allows conclusions to be drawn about the reproducibility of the results.

Measurement of power

When describing test designs, power is specified as power density in W/cm², pertaining to the sound-emitting surface of the probe. When determining this measurement, the mains intake of the entire ultrasonic homogenizer is often regarded as the basis. The losses, which could be significant in the generator and up to

the probe, are disregarded. It is understandable that such a specification is neither significant nor easy to reproduce.

At the 2nd Meeting of the European Society of Sonochemistry (ESS) in September 1991, the principle of calorimetric measurement of power was presented as a suitable process by Rotoarinoro¹, under the title "Power dissipation measurements in sonochemical reactors". During the measurement of power, the sonication vessel should be used for the standard trials. This vessel is filled with water. The increase in temperature can be measured during a pre-determined period of time, and the power density can be calculated on the basis of specific heat capacity, temperature increase and time elapsed, using the usual formula.

Here, the following formula applies²:

$$P/V = \frac{c\Delta\vartheta}{\Delta t}$$

The following applies:

P/V	power density in water [W/cm ³]
P	power [W]
V	test water volume [cm ³]
c	specific heat capacity $\left[\frac{\text{J}}{\text{kg} \cdot \text{K}} \right]$
Δt	period of time between measurements of temperatures [s]
$\Delta\vartheta$	temperature difference between measurements of temperatures [K]

The input of energy in test series can be documented using this method.

¹ Rotoarinoro, A.M. Wilhelm, J. Berlan, H. Delmas "Power dissipation measurements in sonochemical reactors" in: Report on the 2nd Symposium of the ESS; 1991; p. 109 et seq.

² Please note: The formula is only adequate for small volumes.

The SONOPULS ultrasonic homogenisers are not regulated on constant electric power! SONOPULS ultrasonic homogenisers are regulated for constant probe amplitude by the AMPLICHRON system!

When conducting a reaction and reproducing it, the constancy of the amplitude is of special importance. All effects resulting from warming of the probe or changes in viscosity are thus eliminated. This means that the measurement of power must be conducted in accordance with the described procedures, always using identical liquids and the same starting temperatures.

Pulsation

All SONOPULS ultrasonic homogenisers are equipped with a pulse function. It enables to split the processing time in working and resting intervals. Caused by this intermitting process the sonication of heat-sensitive samples will be facilitated. This fact has to be considered when sonicating smallest samples or tough micro-organisms with long processing times.

■ Please contact us for product recommendations for your application fields!

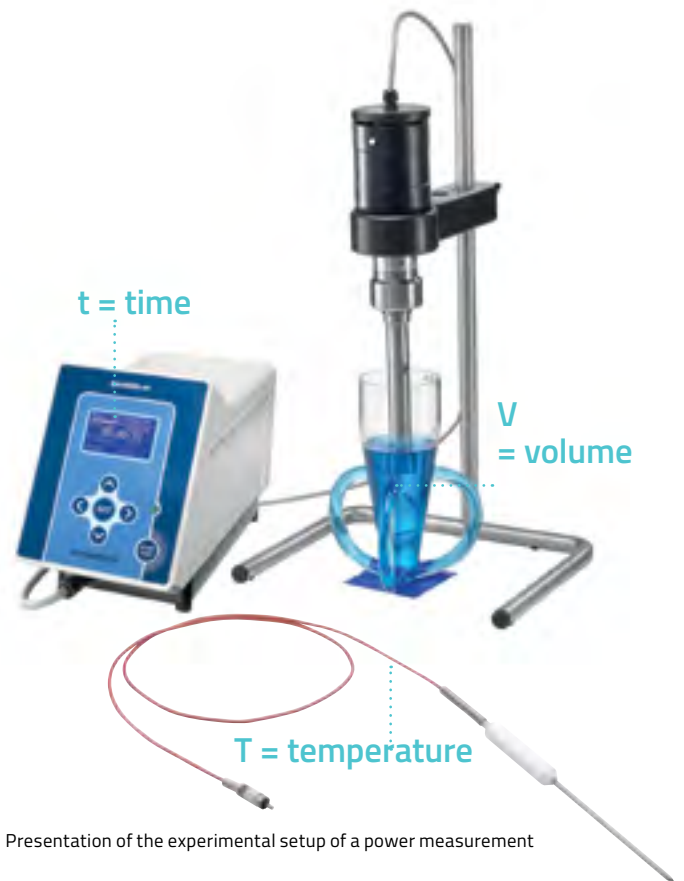

Presentation of the experimental setup of a power measurement

4.3 Choosing a device

4.3.1 Introduction – selection options

The wide range of devices and accessories on offer makes it easy to put together the optimal equipment for the respective application:

- Selection of SONOPULS series
- Type of probe
- Direct or indirect sonication
- Flow-through sonication
- Cooling during sonication

Even if a device is initially procured for individual first applications, a wide range of adaptation possibilities for further applications is available through the subsequent purchase of different accessories.



4.3.2 Overview of application fields and equipment of device series

There are currently three SONOPULS series available. The following criteria apply as general guidelines:

Device series HD 4000

For volumes of approx. 0.5 ml to 3 l in stationary operation or up to 100 l/h in flow-through operation, advanced operation and setting of relevant parameters such as amplitude / power, time and pulsation with freely selectable time intervals, temperature measurement, RS 232 interface, + sequencing, different ultrasonic converter types can be connected.

The following figures designate the power category of the respective device: HD 4050 = 50 W, HD 4100 = 100 W, HD 4200 = 200 W, HD 4400 = 400 W

Device series HD 2000.2

For volumes of approx. 2 ml to 1 l in stationary operation or up to 30 l/h in flow-through operation, simple operation and setting of basic parameters such as amplitude, time and pulsation with freely selectable time intervals.

mini20

Suitable for particularly small sample volumes of 0.1 – 25 ml in the μ l range, for vessels such as Eppendorf cups, autosampler tubes, etc., preferably for manual handling.

The following table provides a more detailed overview of the application fields.

SONOPULS Series 4000, 2000.2 and mini20

Ultrasonic homogenisers in comparison



	Series 4000	Series 2000.2	mini20
	ADVANCED	BASIC	SPECIAL
Sample volumes in - batch operation - flow-through operation	0.5 – 3000 ml up to 100 l/h	2 – 1000 ml up to 30 l/h	0.1 – 25 ml
Possible probes Ø [mm]	2/3/4/6/9/13/16/19/25/32/38	2/3/6/13/19/25	1.5/2.0/2.5
Possible configurations: Ultrasonic generator GM Ultrasonic converter UW	GM 4200 + UW 200 or UW 100 or UW 50 GM 4400 + UW 400 or UW 200	GM 2070.2 + UW 2070 GM 2200.2 + UW 2200	GM mini20 + UW mini20
Amplitude specification	10 – 100 %	10 – 100 %	10 – 100 %
Automatic amplitude limitation	following insertion of attached probe	following insertion of attached probe	following insertion of attached probe
Pulsation	working intervals 0.2 – 600 s resting intervals 0.3 – 600 s	working intervals 1 – 60 s resting intervals 1 – 60 s	working intervals 0.1 – 60 s resting intervals 0.2 – 60 s
Time setting	9 h: 59 min: 59 s or continuous operation	59 min: 59 s or continuous operation	59 min: 59 s
Safety shutdown	9 h: 59 min: 59 s	9 h: 59 min: 59 s	59 min: 59 s
Display elements	alphanumeric LC display for ampli- tude, pulse level, time, energy input and temperature (optional)	alphanumeric LC display for ampli- tude, pulse level and time	alphanumeric LC display for amplitude, pulse level, time and energy input
Power display	in kJ	–	in kJ
Temperature display and measurement	optional, 0 – 120°C, temperature sensor required, optional acoustic signal or switch off	–	–
Batch operation Sequencing	✓ multiple sequential batches	–	–
Remote control via PC	RS 232 (D-sub)	–	RS 232 (infrared)
Error diagnosis	✓	✓	✓
Operating frequency	20 kHz	20 kHz	30 kHz
Data memory	✓, 9	–	✓, 9
Functional check	✓	–	✓
Mains connection	230 V~ (±10 %), alternativ. 115 V~ (±10 %), 50/60 Hz	230 V~ (±10 %), alternativ. 115 V~ (±10 %), 50/60 Hz	100-240 V~, 50/60 Hz

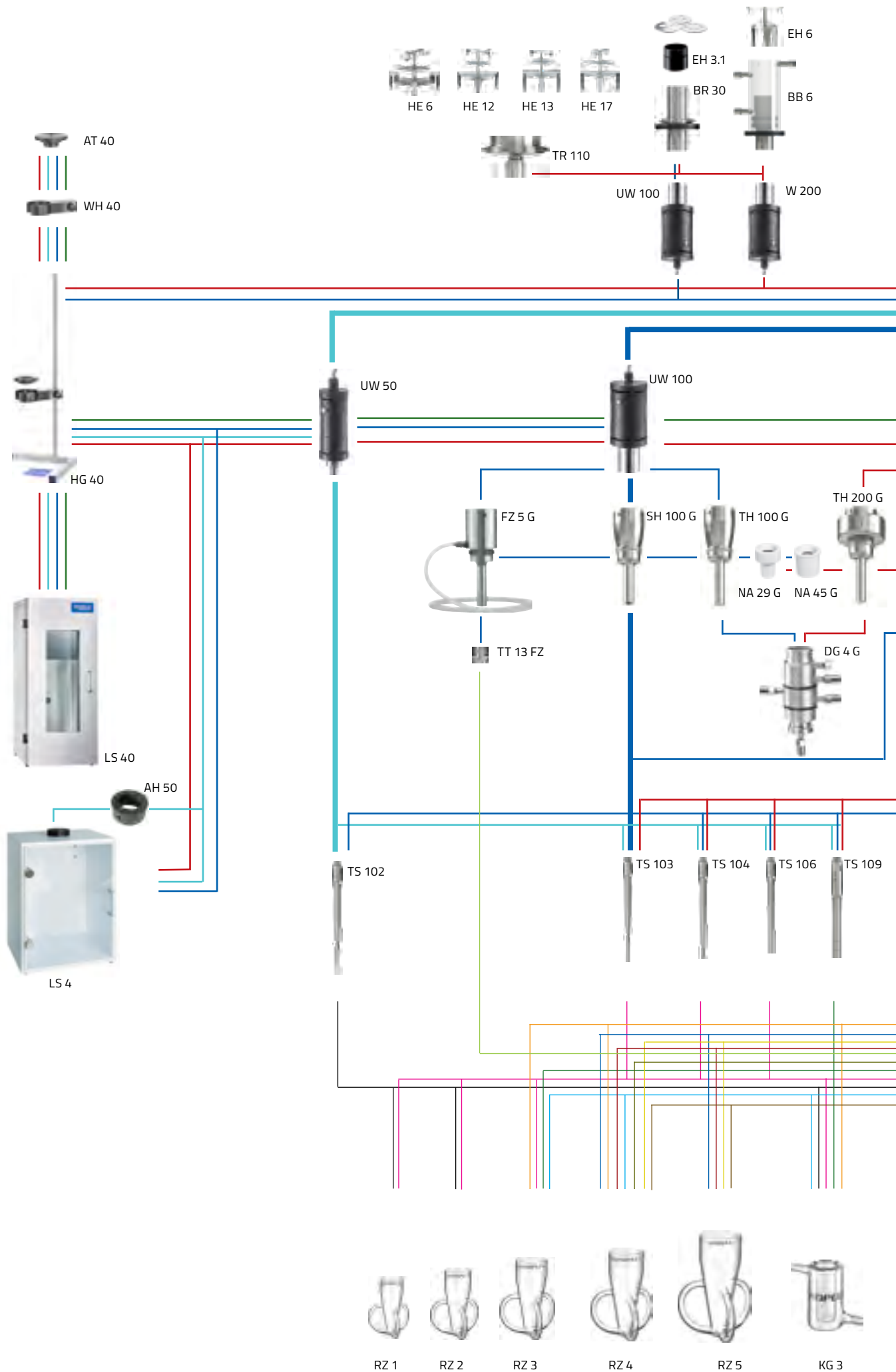

HD 4050
HD 4100
HD 4200

HD 4400

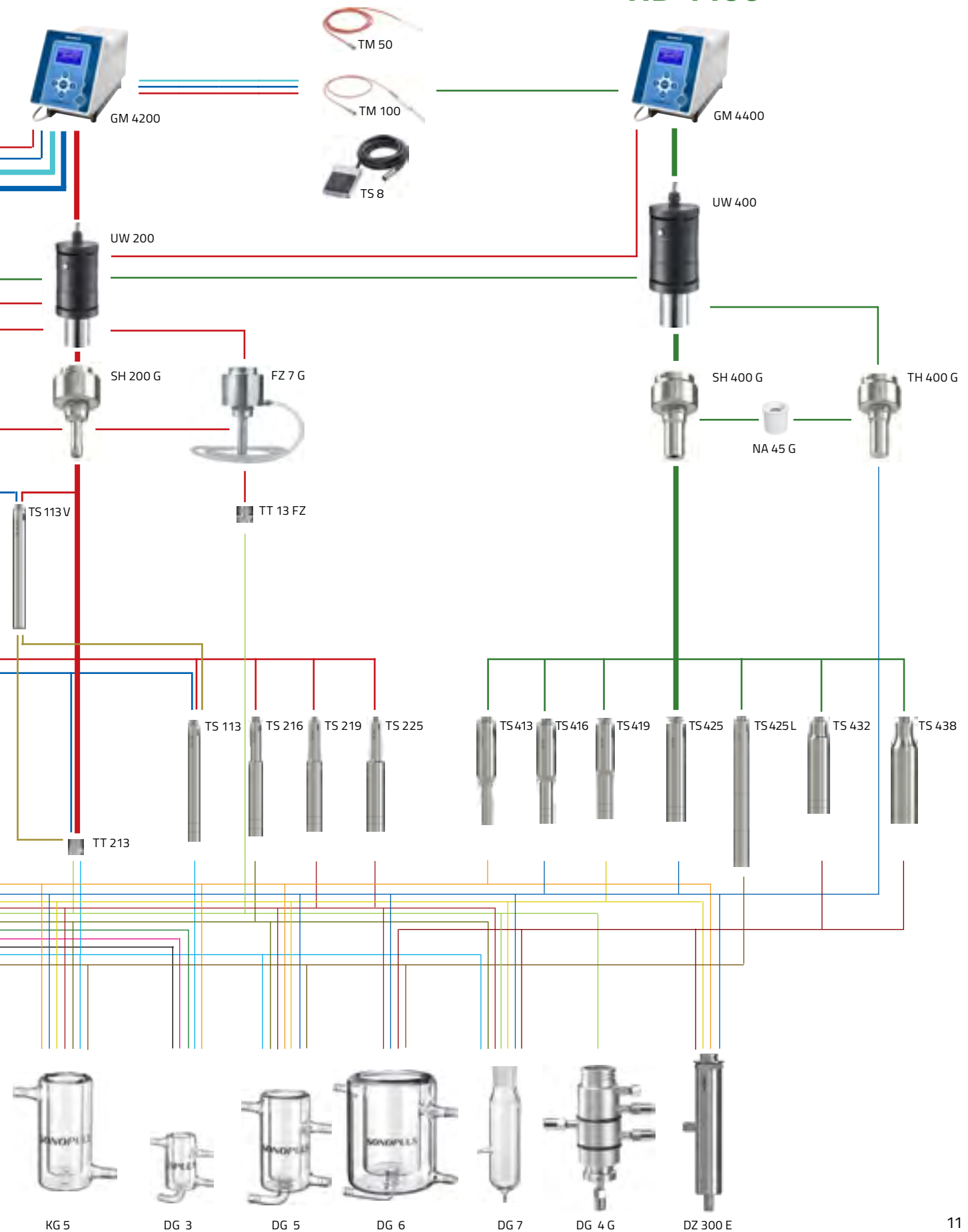

HD 2070.2

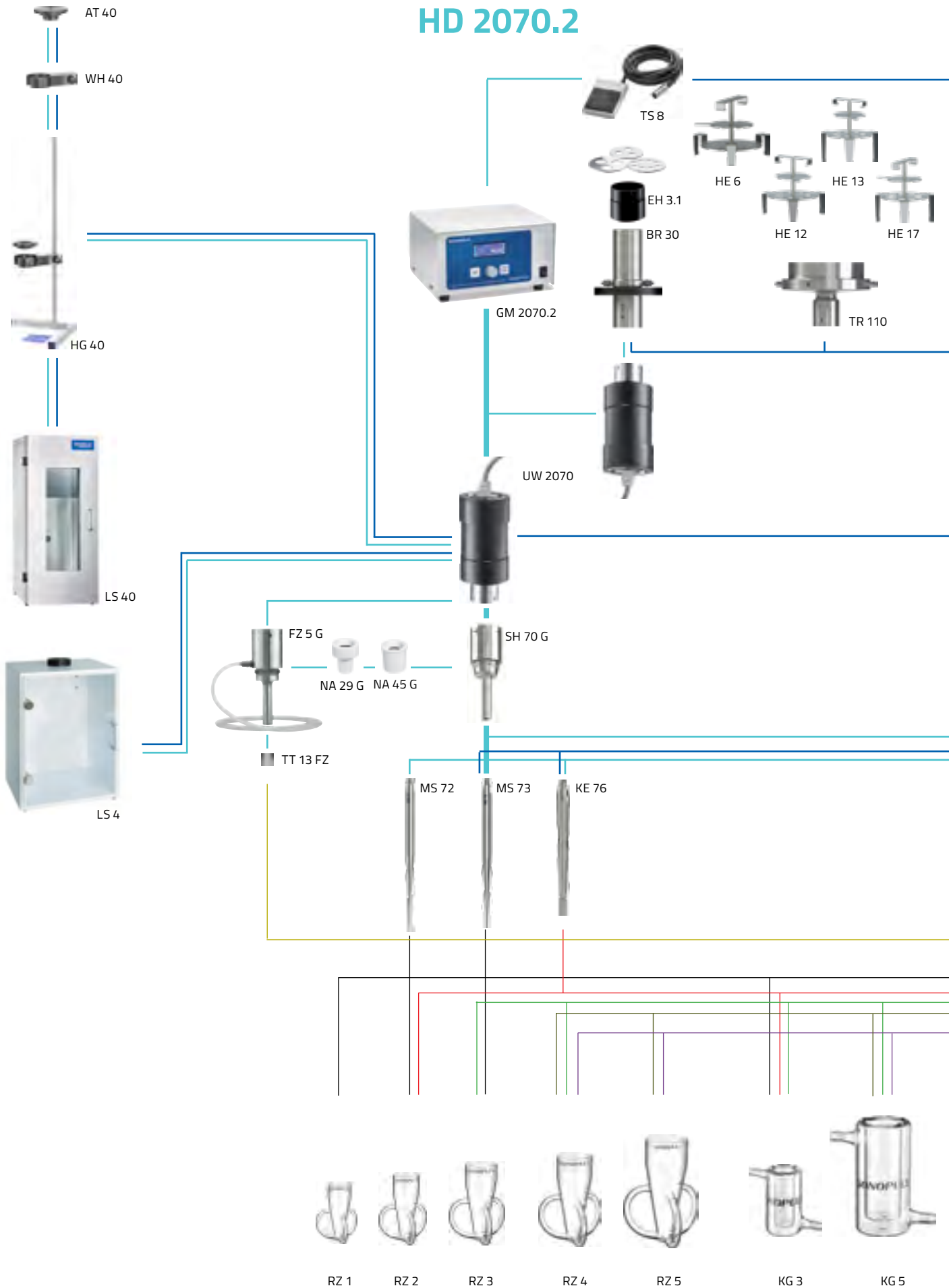

HD 2200.2

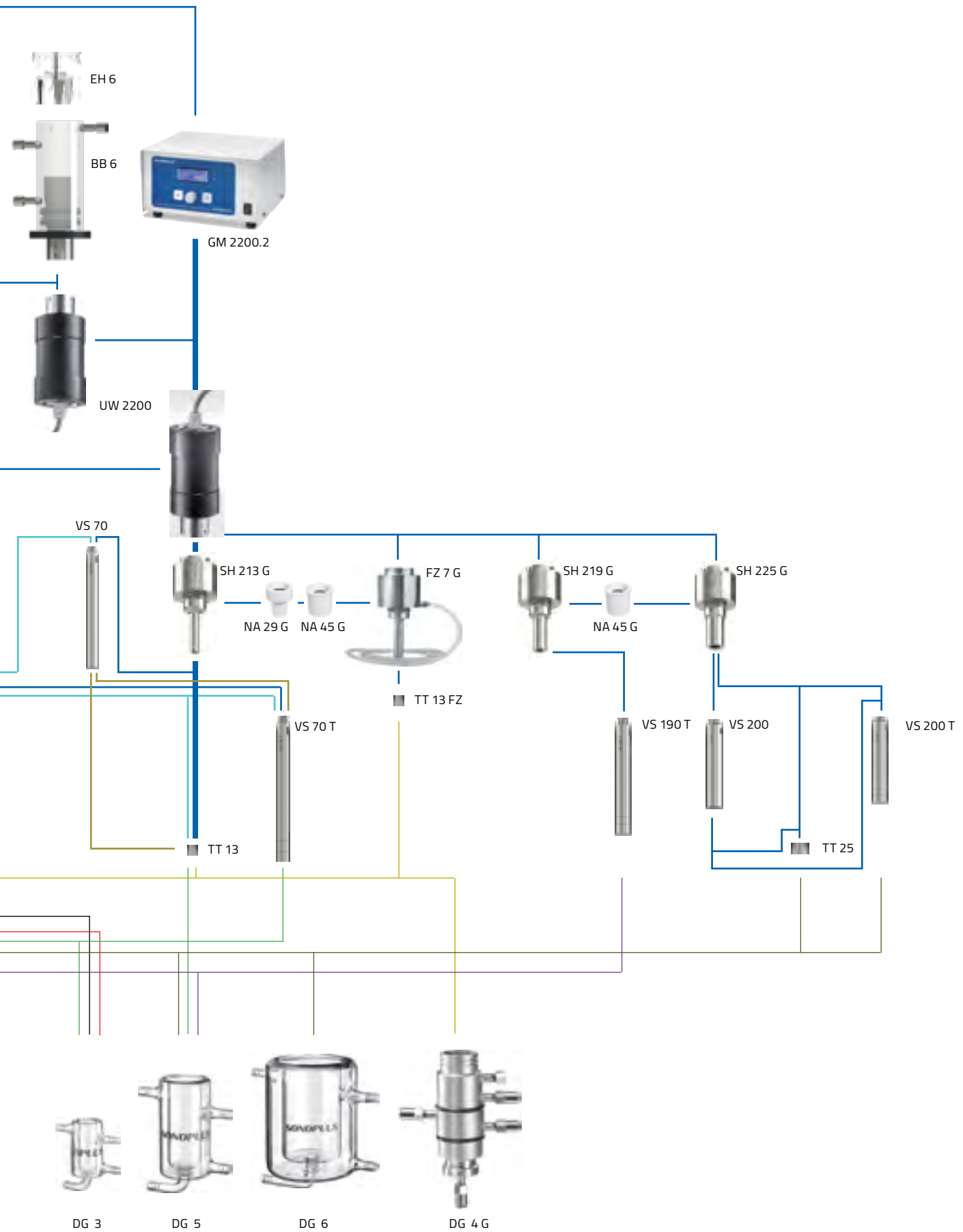

4.3.3 Selection and use of the probes

The probes are thermally stable, autoclavable and resistant to practically all corrosive media. They are produced from a titanium alloy (TiAl6V4 / 3.7165).

Which probe is best suited?

The probe selection is based on the sonication volume and the desired power density [W/l]. Each probe has an approximate recommended range of sample volumes.

It is only a guided value to follow. The volume to be sonicated is depending on the application. For example, the 1/2" probe mounted to UW 200 can process volumes between 20 and 900 ml. Depending on size and shape of the processing vessel, it could be difficult to place the 1/2" probe into a 20-ml-vessel. In this case a micro tip may be the better option. Therefore, size and shape of the sample vessel are determining factors for selecting the appropriate probe.

Probes with a small radiating surface are used for sonicating samples in vessels inside small and thin, but never for sonicating samples larger than 50 ml. These probes work with high intensities and are appropriate for short processing times. Especially probes with small radiating surfaces (so called micro tips) generate a considerable amount of heat in small volumes. Pulsed mode should be used when processing temperature-sensitive samples in order to prevent heat-up.

Larger volumes require probes with larger radiating surfaces. For example, a 38-mm probe is more effective than a 25-mm-probe when sonicating 1 litre. A conical shaped vessel is best suited without splashing as the probe can immerse deeply enough into the sample – there is no violent motion on the surface. Another way to process smallest samples is an indirect sonication (chap.4.3.4). However, the power density decreases. A very high power density is required for the disruption of yeast cells, for example. The sound is only emitted from the tip of the probe, not the sides!

The sonic distribution conforms to a row of "hemispherical shells" increasing in radius the further they are from the sound-emitting surface (see illustration below). The power density decreases at the same time.

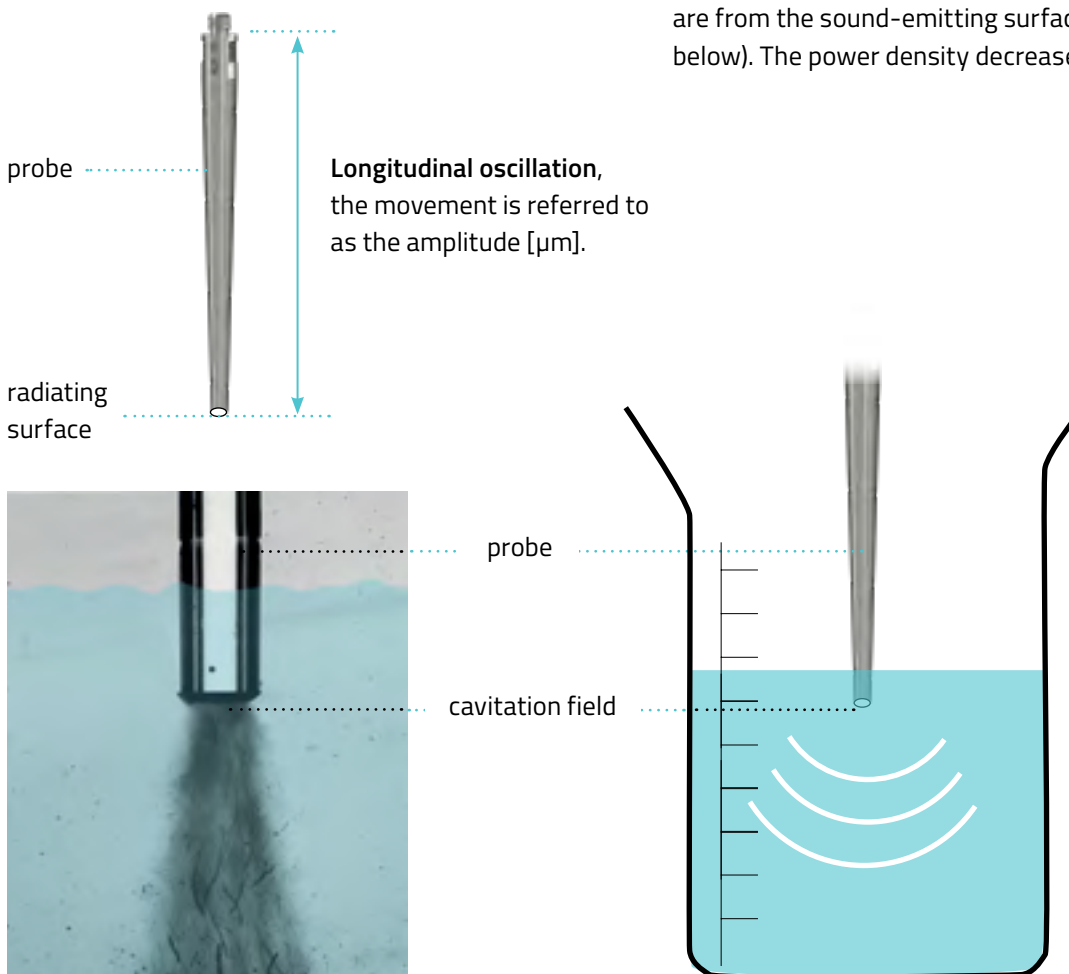

The smaller the diameter of the probe tip, the higher the power density and cavitation power for the same electrical power consumption!

The cavitation process is associated with erosive material abrasion on the probe tip. This becomes evident as a "pitted landscape" on the sound-emitting surface of the probe (see chap. 4.4.2) after a period of operation. The higher the amplitude, the higher in turn the material abrasion, with the service life becoming correspondingly shorter. In other words, the smaller the diameter, the shorter the service life at the same output. If used in continuous operation (100% amplitude, no pulsation), a probe with a small radiation surface can last approx. 6 hours. The use of a probe with an appropriate radiating surface not only reduces the processing time, but the life time of the probe is increased, too. However, the majority of applications last but seconds or minutes. In some cases, this wear is undesirable as it always mixes with the medium to be sonicated (for example, in sample preparation for metal analysis or similar).
Avoidance of abrasion – see "Indirect sonication".

Basic probe designs and their application characteristics

In combination with the power of the ultrasonic generator, its design determines the maximum possible amplitude and the energy transferred to the medium. For this reason, the sound intensity transmitted to the medium is inversely proportional to the probe's sound-emitting surface. This means that probes with the smallest sound-emitting surfaces transmit the highest powers per surface [W/mm^2] through high amplitudes, depending on the ultrasonic generator's electrical power consumption.

Micro tip (in combination with mini20 only)

conical / stepped shape,
used to process small volumes
in reaction cups or centrifuge tubes



Tapered tip

conical shape, used to process medium-sized



Long probes

rod-shaped, used to
process larger volumes in beakers



Stepped probe

broad range for smallest
to larger volumes of approx.
 μl quantities up to 3 l

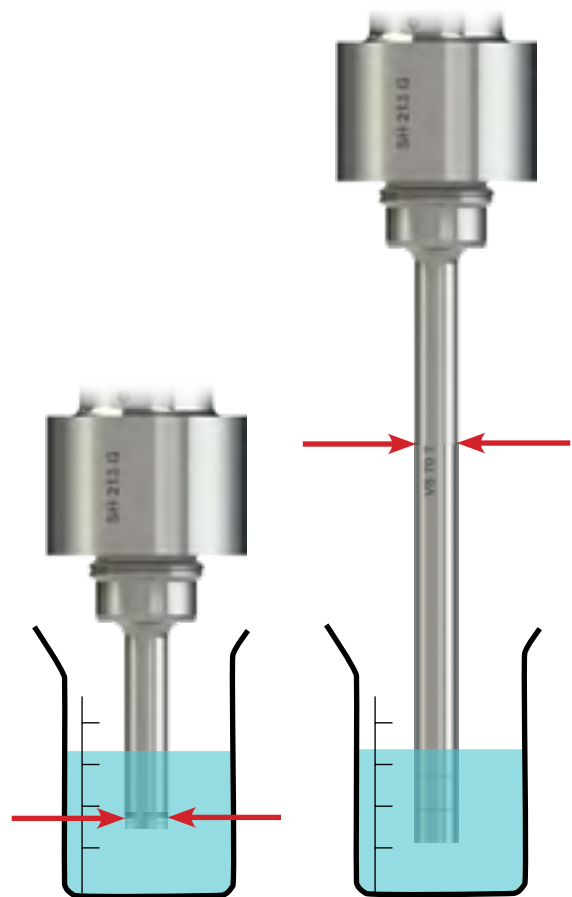

screw connection horn /flat tip and horn/probe, cylindrical

Flat tips vs. solid probes

The screw connection horn/flat tip is immersed into the sample to be sonicated. Sample liquid or smallest particles can penetrate the screw connection (the less tight the connection, the higher the wear at threads and mating surfaces!)

Due to the heavy stress on the screw connection during sonication, the threaded stud of the flat tip "hits" back and forth in the thread of the horn. This is followed by damaging mating surfaces of flat tip and horn - a hair-line gap is created. The amplitude can no longer be controlled at the generator.

When using solid probes (long), sample material cannot seep inside the connection as this connection does not immerse into the sample.

4.3.4 Sonication under special conditions

Cooling of samples

The sonication results in the conversion of mechanical power into heat through internal friction in the liquid, and thus to a more or less pronounced heating of the sample liquid. As such, cooling may be necessary for temperature-sensitive samples. Sample vessels can be



cooling vessel KG

placed in an ice bath or vessels with a cooling jacket can be used, which are connected to a cooling system.

Flow-through sonication of sample liquid

Flow-through volumes of up to 100 l / h are possible for the sonication of larger sample sizes. There are both glass and stainless steel vessels available. The stainless steel vessel is "hermetically sealed" when connected to the booster horn (overflow is also closed), which enables the sonication of infectious substances. The solution can also be introduced into a circuit for intensification of the sonication process. The double wall of the vessels makes cooling possible.



Flow-through vessels DG 5 made of glass and DG 4 G made of stainless steel for tight sealing to the booster horn



Example set-up with flow-through vessel DG 4 G

The sonicated medium is introduced from below, in other words head-on to the probe's sound-emitting surface. The sonicated medium comes into contact with the cavitation field as a result of the short distance between the sound-emitting surface and the bottom of the vessel. It has to pass through the cavitation field in order to continue flowing.

Merging of two media (DG + FZ):

A flow-through horn FZ is used instead of a stepped or booster horn. The first medium is introduced into the sonication chamber via the inlet of the flow-through cell, the second via the inlet of the flow-through horn. This medium enters the sonication chamber via the outlet in the sound-emitting surface. Both media can thus be well mixed, even in different ratios (see image).



Example set-up with flow-through horn FZ 7 G and flow-through vessel DG 5

Indirect sonication

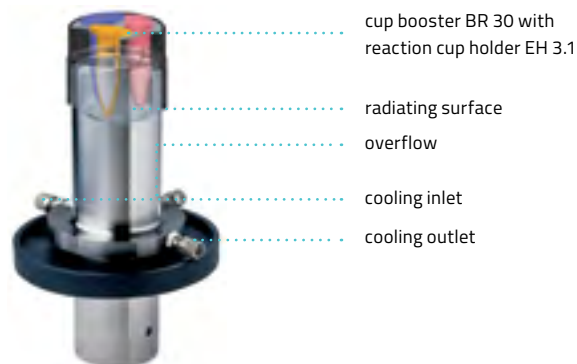

Indirect sonication eliminates the need for the probe to come in contact with the sample. The process can be compared with a high-intensity mini ultrasonic bath. The ultrasonic energy is transferred via the contact liquid in the cup booster to the sample vessels/tubes while they remain closed. Indirect sonication is especially suitable to process smallest samples (less μm) as foaming and sample loss are prevented. Intrusion of material removal of the probe into the sample as well as cross contamination are eliminated. A sample cooling is always possible. We recommend connecting a recirculating cooler. A constant filling level has always to be considered and a floating of the reaction cups has to be prevented.

Otherwise sonication results could be affected. For cooling crushed ice can be added to the water inside the cup booster but a constant temperature cannot be realized for a longer time. When using crushed ice place it on the sides of the reaction vessels and not below. This could reduce the effectiveness.

Connection to special laboratory vessels



Vessels with the standard ground joints NS 29/32 or NS 45/40 are often used for chemical reactions in laboratories. There are standard ground joints made of PTFE available for ensuring a tight seal between the vessel and the homogeniser.

They are screwed onto the external threads of standard / booster or flow-through horns and inserted into a vessel with standard ground joint.

Optimised operation

In addition to using the START / STOP button on the ultrasonic generator, the device can also be operated using a foot switch or a button on the ultrasonic converter.

The RS 232 interface can be used to read out data via the device or exchange commands, making it possible to control the device remotely or log process parameters, for example.

Noise reduction

The cavitation process is associated with noise development, which increases correspondingly with a higher amplitude / power, but also depends on other factors such as temperature, sonicated medium, volume, filling level or immersion depth of the probe. This can often be disruptive at the workplace. Therefore, we recommended the use of a soundproof box. This can reduce noise by up to 30 dB(AU) (as per IEC 61012).

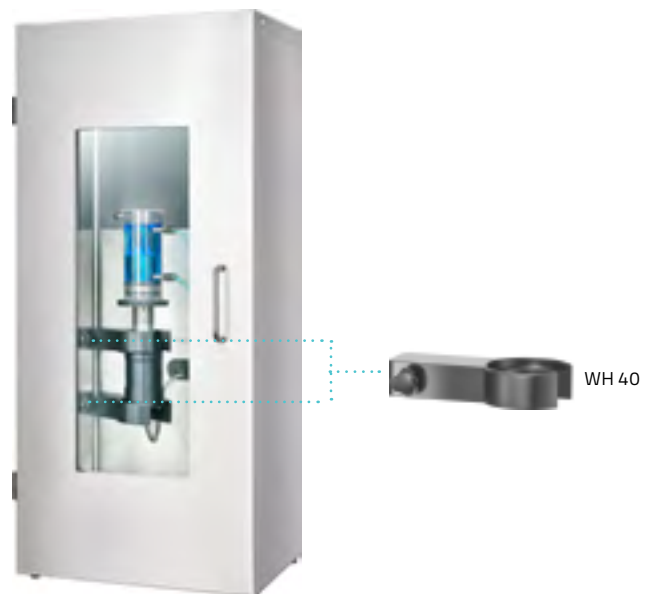

4.4 Selection of method parameters

4.4.1 Introduction

The success of sonication with the ultrasonic homogeniser is fundamentally dependent on the correct selection of the device and method parameters. On the basis of the previous versions and / or a consultation with BANDELIN employees, you have now selected the right device with the right probe and possible accessories.

The following chapter explains the parameters so as to allow you to identify the suitable method for your requirements and ensure the sonication is successful. As requirements can be very specific, the approach can be selected in such a way that a basic method is chosen on the basis of similar application scenarios, but needs to be modified in a range of initial tests in order to optimise conditions, using the basic knowledge communicated here so as to suit the individual requirements.

4.4.2 Basic information concerning use

Selection of vessels

In theory, you can use any vessels made of any material (glass, plastic, etc.). A narrow vessel is preferable to a wide vessel. The ultrasonic energy is generated from the radiating surface of the tip and is directed downward. The sample liquid is pushed down and away in all directions. If the vessel is too wide it will not mix effectively and some sample will remain untreated at the periphery. However, there is a good experience with rather narrow and conical shaped vessels. An optimal power transmission is guaranteed and splashing is prevented. With the so-called rosette cells offered as accessories, a higher degree of circulation can be achieved.

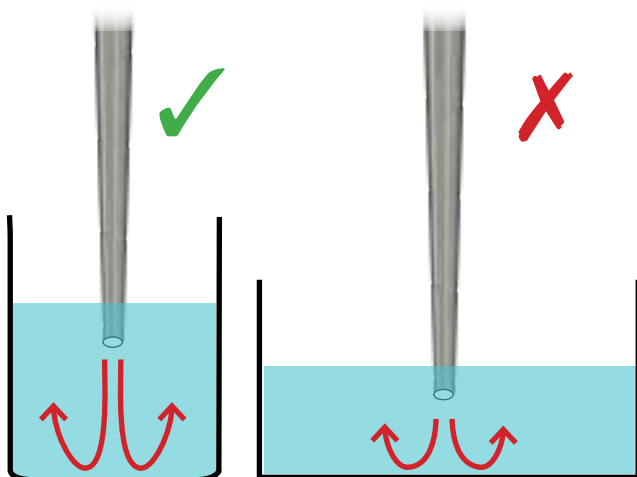

The ultrasound pressure forces the sample against the bottom of the vessel and then through the three side arms, so it is sonicated repeatedly. When placed in crushed ice, for example, the sample liquid is cooled very well and effectively thanks to the side arms and the uninterrupted circulation.



Visualisation of the intensity areas in a rosette cell
Source reference: Beuth Hochschule Berlin

Fixation of the ultrasonic converter

The ultrasonic converters may only be held by the black housing, for example using a stand clamp. Improper clamping/fixing can lead to malfunctions or mechanical faults. For example, the preset amplitude is not reached and an error displayed.



Immersion depth of the probe

Probes must be immersed correctly, normally approx. 1 cm. If the probe is not submerged enough the sample tends to foam or splash. If the probe is immersed too deep the sample will not circulate effectively and on the other hand the probe can be damped too much laterally (especially with highly viscous media). Both will end up with poor results.



The immersion depth of the probe is often difficult to see, as either the sample liquid is too dark or the reaction vessel is placed in ice. Our probes with larger diameters (1) have markings in the lower area to control the immersion depth. When working with so called micro tips (2), we recommend filling the reaction vessel with water to match the desired sample volume. The micro tip has to be inserted to the optimum depth. To indicate where to stop inserting the micro tip a horizontal line has to be drawn with a permanent marker on the micro tip. So the correct immersion depth can be ensured each time.



Sonication of a chunky sample in a liquid

In many cases, mechanical grinding of the sample is necessary in advance, as ultrasound is significantly more effective on smaller particle sizes. If chunky samples are to be sonicated, the probe should be positioned directly on the sample.

Probes with "pitted" surfaces

The probe tip wears away with use (see chap. 4.3.3). At the same time, the efficiency of the sonication deteriorates and the reproducibility of the sample sonication becomes poorer. The smoother the sound-emitting surface, the better the power output in the medium. Sand the probe while the pitting is still minimal (see instructions for use). If the pitting is deeper than approx. 1 mm, the probe should be reprocessed by BANDELIN or replaced.



Mounting of probes

Here it is imperative to ensure that a minimal torque [Nm] is always reached so that a stable mechanical connection between the probe and horn is always guaranteed. We recommend the use of a torque spanner to ensure a reliable mechanical contact and thus correct function (please consult the corresponding product information for the tightening torques). The same applies when changing the horn on the ultrasonic converter.



https://www.youtube.com/watch?v=tT6YBP_tDKM

Further information

For minute volumes, we recommend immersing the probe as far as possible so as to avoid significant movements on the sample surface.

If the sample still foams, try working with a lower amplitude, cooling the medium and / or selecting the pulse mode. If necessary, glass beads ($d = 0.5$ mm) can also be added. These beads sink to the bottom following sonication and can be centrifuged out. Conical vessels and vessels with irregular interior surfaces are best suited for the sonication of minute volumes in order to prevent foaming.

4.5 Setting the sonication parameters

4.5.1 Amplitude

The amplitude is set to control the power input level and the extent of the cavitation strength. The value is selected as a percentage of the probe's maximum amplitude. The amplitude must be high enough to achieve a good sonication result. If the amplitude and sonication time, and therefore the power application, are too high, the result may be unnecessarily heavy heating, splashing or foaming of the sample liquid or possibly a destruction of the sample components. Settings guidelines can be taken from our application examples or determined in tests.

4.5.2 Pulsation

In the standard setting, the power is transferred to the sample continuously during sonication. In such cases, the device works in continuous operation (non-stop mode).

There are applications in which it can be practical to apply the energy in time intervals. Indications for pulsation include undesirable, rapid heating of the sample, desired settling of the sample on the bottom of the vessel, or allowing reactions to occur during the pauses.

4.5.3 Sonication time

In stationary operation, the sonication time is generally between 15 s and 5 min. Similarly to what applies for the selected amplitude, since too short a sonication period may be insufficient for the desired sonication result. Prolonged sonication, in contrast, may result in an unnecessary temperature increase of the sample or even affect the properties of the sample. Last but not least, it may result in an unnecessary increase in the processing efforts required. It is thus advisable to select a tendency for the sonication time based on the applications outlined in chap. 6, and then to analyse in a series of small tests which duration is optimal for the actual application, as there is no 100% correct answer for each type of vessel, sample volume, concentration, etc.

4.5.4 Cooling

Depending on the conditions, the applied power is converted to heat and can thus result in considerable temperature increases in samples with small volumes. The heating can be influenced using the parameters described above: amplitude, pulsation and sonication time. It is necessary to check whether the heating still occurring has a negative effect on the sample. If so, cooling of the samples is recommended. This can be easily done by positioning the sample vessels in an ice bath or crushed ice. Alternatively, double-walled vessels which allow water cooling can also be procured from our range.

4.5.5 Use of beads

When using particularly solid material, it may be useful to add glass beads to the solution, as these intensify the effect of the ultrasonic cavitation. Depending on the application, glass beads in different sizes (up to 0.5 mm in diameter) and different quantities may be added. A ratio of 1/3 glass beads to 2/3 solution often delivers good results. The beads settle to the bottom of the vessel after sonication and can be centrifuged or filtered out. Higher probe wear also needs to be taken into account when using beads.

5 Overview of applications

The number of possible applications is very high and the range of application areas especially broad, with new ones being added all the time. The most important procedures and branches in which the ultrasonic homogeniser is used in laboratories or the sonoreactor at production level, are listed below. Regard it as inspiration for your own situation, as the ultrasonic homogeniser or sonoreactor might represent a viable solution.

5.1 Basic procedures

5.1.1 Dispersing: suspending, emulsifying

Dispersing is a procedure in which substances which do not or barely dissolve in one another, are mixed together optimally. A distinction is made between different types of dispersion depending on the dispersing medium and the dispersed phases.

- **Emulsion – liquid in liquid** (dispersed phase)
- **Suspension – solid in liquid**

Ultrasonic homogenisers can achieve great results when emulsifying as well as suspending. Particles are disagglomerated and electrostatic attractive forces (Van der Waals forces) perturbed. The high forces (see basics of ultrasound) make it possible to achieve very finely dispersed emulsions / suspensions with very small droplet or particle sizes in the micrometre and nanometre range, which leads to very good stabilities of the resulting emulsions / suspensions. The clumping, agglutination, sedimentation and undesirable inclusion of air experienced with other methods do not occur. Application examples include the production of ink, paints, cosmetics, technical oils, etc.

A particular explosion of applications has been observed in the area of nanoparticles in recent years. Here, it is possible to achieve particularly good dispersion results with regard to the average particle size and particle size distribution, using ultrasound.

Ultrasonic sonication is possible in all size ranges, from μl right up to production levels via upscaling.

The sonication can be performed discontinuously or in flow-through. One example is the production of pharmaceutical preparations, especially minutely dispersed emulsions such as lotions and ointments.

When mechanical homogenisers are used, excessively slow stirring often results in separation of the liquid, and excessively fast stirring leads to the undesirable inclusion of air.

The ultrasonic homogeniser produces a physically stable emulsion!

The applied amplitude is decisive for the yield of the droplet comminution.

5.1.2 Homogenising

If ultrasound is used for homogenising, the particles (solid or liquid) are comminuted in a liquid, resulting in more intensive mixing. There is a wide range of application possibilities. See below for further information on homogenising in sample preparation for analysis.

5.1.3 Extraction

The extraction of ingredients from solid particles in the liquid phase represents yet another extremely interesting field of application. The possible advantages to be achieved for many applications, in comparison with other extraction methods, are:

- higher yield,
- shorter extraction times,
- lower required temperature,
- lower proportion of solvent or
- complete conversion to aqueous phases.

A combination of ultrasound and other extraction methods is also practical in some cases. The application can be customised to the requirements, and upscaling to production processes is also possible with excellent results. One example of this application is the extraction of mineral components from the soil in the scope of sample preparation for analysis. The extraction is completely finished after 10 seconds, whereas it has to be shaken for 1 hour in the conventional shaker.

5.1.4 Disagglomeration

Agglomerates can be very effectively destroyed with an ultrasonic homogeniser. For example, this is employed in sample preparation for particle size analysis, as preparation for cell count determination in microbiology, for the production of stable protein solutions, etc.

The high variability of the power input makes it possible to ensure that precisely the right amount of power that is required for complete disagglomeration without degrading the particles, cells, etc., is applied.

5.1.5 Degassing, defoaming

The removal of air or other gases from liquids is essential for further use in a variety of scenarios, for example for HPLC eluent, for the analysis of sparkling drinks, for the degassing or defoaming of emulsions, varnishes, etc. Degassing or defoaming with an ultrasonic homogeniser is very fast, simple and effective. Even large sample volumes, including chemical solutions, can be degassed with ultrasound. This is mostly carried out in a flow-through cell that can also be integrated in a production line where, for example, gas is to be expelled from a fluid (a degassing opening must be present).



5.1.6 Sample preparation for analysis – homogenising, extracting, disagglomerating, degassing

These procedures are widely used in the preparation of samples for analysis and are particularly efficient and simple in their use compared with the available alternatives. The sonication takes just a few seconds or minutes. The preparation, use and cleaning are exceptionally simple and uncomplicated. Dismantling of the device for cleaning is not required. An autosampler can be used.

Examples of applications include:

- disagglomeration as sample preparation for particle size analysis
- homogenising of waste, wastewater, food samples for content analysis
- extraction of components, for example minerals from soil, etc.
- degassing of sparkling drinks for undisturbed analysis of the contents

It is possible to sonicate volumes from μl quantities up to 3,000 ml in stationary operation, and up to 100 l/h in a flow-through vessel made of glass or stainless steel. The solution to be treated can also be routed through the sonication vessel multiple times in a circuit.

In the case of samples consisting of large pieces, comminution in advance is often practical. If necessary, simple cooling is also possible (ice bath, flow-through cooling jacket). The pulsation mode (cyclical sonication) avoids rapid warming on the one hand, and achieves good swirling of the sample on the other.

Long probes are especially suited for the sonication of ceramic suspensions or for sample preparation for particle size analysis, for example.

5.1.7 Disruption of cells, microorganisms and tissue

The ultrasonic homogeniser has been established as the standard method for disruption of cells of all types, for decades. It is possible to disrupt bacteria, yeasts, fungi, eukaryotic or plant cells, tissue, algae and even microalgae. The broad range of variation of the power input is particularly relevant in this respect, as it allows control over the degree of disruption. Fragmentation of DNA, for example, is also possible if desired. An excessively high power input may lead to a high degree of disruption or to unnecessary heating of the sample. Cooling is recommended for the majority of cases, in this respect. To some extent, indirect sonication is also given preference. Even very small quantities in the μl range can be sonicated well and with ease.

Cell disruption

Sonication with an ultrasonic homogeniser makes it possible to achieve short disruption times, especially for bacteria. 20 ml of a 20% yeast cell solution can be disrupted in 20 min (use of glass beads). In the case of animal cells, which are encased in only one outer membrane, a significantly shorter disruption time is achieved than with alternative methods. The time needed ranges from only a few seconds to 5 min.

In the case of plant cells, up to 15 min are needed since the cells possess one additional shaping membrane. Thermal damage to the cell contents can be prevented by employing pulsation, i.e., periodic interruption of the power supply. In addition, respectively suitable time intervals can be set on the device. Cooling down is possible during the pulse pause.

In addition, cooling vessels made of glass or stainless steel may be used, making temperature control through the use of liquid cooling agents possible during sonication.

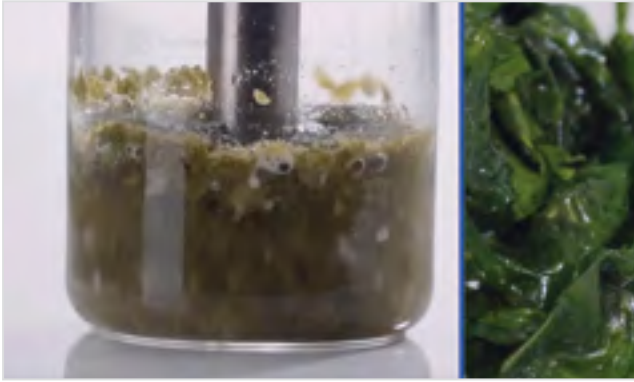

The use of rosette cells, in which the sample is repeated and evenly sonicated thanks to the design of the side arms, is also suitable. Cooling is possible with ease, for example by positioning the vessel in an ice bath. Larger quantities can be sonicated in a flow-through vessel which, just like the cooling vessels, is also equipped with a cooling jacket.

Direct sonication with micro tips is helpful for particularly-resistant bacteria, fungi and spores, since this method makes a higher power density possible. It should be mentioned again at this point that the probes are produced from a titanium alloy and are thus both thermally stable and autoclavable.

Direct sonication of μl quantities in 2 ml plastic vials with the SONOPULS mini20 is regularly employed with success in practice. Alternatively, μl quantities can also be sonicated indirectly in the beaker resonator. This can prove the better alternative if too intense splashing occurs in direct sonication. However, the attainable power densities are lower, but cell disruption is still possible in many cases.

Tissue disruption

Another interesting application is the use of ultrasound for tissue disruption, particularly for difficult tissues such as the brain, liver, bladder, aorta, kidneys, lungs, skin, muscles, bone, heart muscle and fibrins. If an intact piece of tissue is sonicated, the piece of tissue and the probe must be in contact. Possible rapid heating of the sample may render cooling necessary. The material, shape and size of the sample vessel are also decisive. Sample vessels made of thin glass, such as Pyrex or Vycor, have a tendency to break when the probe is pressed against the walls of the vessel. The use of stainless steel centrifuge tubes and "cold shoulder cooling cells" is recommended. These are thin stainless steel test tubes with a comb shape on the sides and a dimple on the bottom. The comb shape

increases the transfer of heat and the dimple provides a "resting place" for the tissue. If the cell is placed in an ice bath, the temperature of the tissue can be kept at 5°C using a magnetic stirrer.

With skin, effective disruption is only possible if the probe is placed on the tissue and pressed against the bottom of the vessel. Even faster results are obtained if glass beads (diameter up to 0.5 mm) are added to the solution, which fall to the bottom of the vessel after sonication and can then be centrifuged or filtered out. A good ratio is 1/3 glass beads to 2/3 solution. With this approach, 4 minutes are required for the disruption of 1 g of skin. If it is not possible to add glass beads, enzymes such as hyaluronidase can be used to dissolve the connected tissue. The sample vessel should be filled with sufficient liquid in order to prevent foaming, although this is only a problem with minute volumes.

It is also possible to place a plastic ring or wire on the surface of the liquid, and thus prevent heavy surface or circular movements. Very small tissue pieces can be well disrupted with a micro tip in a narrow vessel.

Cutting the tissue into small pieces is not especially advantageous unless it is to "flow-through freely" beneath the probe. In such a case, the probe may not be positioned directly on the tissue.

If freezing and grinding are possible, the probe must not touch the tissue. It is also possible to sonicate larger quantities. The following is a simple method for sonicating larger quantities, for example 10 g of liver: The tissue is liquefied for 10 s in a high-speed mixer. The probe is then immersed in the liquid and sonicated for 15 s. If subcellular elements are to remain intact, the operation should use a lower amplitude and perhaps a longer sonication time.

5.1.8 Sonochemistry

The term 'sonochemistry' refers to the use of ultrasound to influence chemical reactions or polymerisation. Effects that are desired and achieved through such use include an increase of the reaction speed and yield overall or of individual reactants / catalysts, or the influencing of the reaction pathway. In some cases, reactions only occur at all if power is applied via an ultrasonic homogeniser. The effects are understandably extremely case-specific and thus the testing and development of methods can prove very beneficial.

5.2 Branches with ultrasonic applications

5.2.1 Biology – Microbiology – Life sciences – Human medicine

The disruption of cells or tissue is an established method for obtaining good results with a wide range of cell and tissue types. With respect to the volumes, there are absolutely no restrictions, whether microvials in labs or applications at production level. More detailed information on cell and tissue disruption can be found in chap. 5.1.7.

Fermentation processes can be activated or accelerated and cells disrupted on a grand scale. A special setup optimises the turnover in biogas plants.

5.2.2 Nanomaterials

Nanomaterials are in widespread use today and there is a whole spectrum of products on offer, so it is not surprising that the range of applications for ultrasonic homogenisers in this field is equally broad. Classic applications include the disagglomeration of nanoparticles in solutions for further use, particle size analysis and the suspension of nanoparticles in solutions for further processing, for toxicity tests, etc.

Ultrasonic homogenisers are also used in the production of nanomaterials, where they contribute to acceleration, controlling reactions, preserving defined particle structures, etc. Further tried and tested applications include the positive influencing of the production of surface coatings and functionalisation / phase transfers of nanoparticles. With respect to the volumes, there are absolutely no restrictions, whether of microvials in labs or applications at production level.

5.2.3 Foodstuffs & drinks

Foodstuffs often need to be homogenised in a liquid phase before they can be analysed. This can be achieved very easily, rapidly and efficiently with the ultrasonic homogeniser. The high power input generates smaller particles and thus achieves a more homogeneous distribution. In many cases, the addition of solvents is no longer necessary and smaller sample quantities can be used. The main area of use for ultrasonic homogenisers is the treatment and preparation of samples, homogenising and extracting all types of substances. The variety of samples is extensive.

The sonication of hard cheese, cottage cheese, salami and ham, for example, has proven very successful in practice. In the beverage industry, degassing via ultrasonic homogenisers is a particularly widespread



practice both for subsequent analysis and for further processing requirements. 0.5 l beer is degassed, for example, in 1 minute at 100% amplitude and 50% pulsation. Microbial processes such as fermentation, cell disruption, enzyme activation, etc., can be supported / performed in a myriad of ways. Autosamplers can be employed for larger sample flow-throughs in sample preparation. All processes such as homogenising, dispersing, suspending, emulsifying and degassing can be performed with sonoreactors in individual setups at production level.

Different companies and investigating bodies have performed a range of reference investigations in combination with universities. At one university, for example, a process for the rapid and gentle isolation of fat was developed for determination of the intramuscular fat and fatty acid pattern in pork. To this end, 50 pork chop samples were investigated. Puréed meat was compared with ultrasound-homogenised meat.

Using the ultrasonic homogeniser made it possible to save both time and energy, plus a smaller sample quantity was required! Furthermore, for example, 50 g of frozen fish were homogenised in less than 1 min without the addition of a solvent. Cheese, especially cream cheese, is often homogenised in practice for sample preparation for analysis (e.g., nitrate determination) with excellent application advantages, namely simple handling and very rapid cleaning. It has been documented that very reliable analysis results are obtained.



5.2.4 Cosmetics

Emulsions and suspensions are the keystones of products as well as development, analysis and production processes in the cosmetics industry. As already described, the sonication with the ultrasonic homogeniser produces emulsions and suspensions with outstanding characteristics combined with simple handling and optimal flexibility in terms of the setting of the properties (droplet / particle size, stability, etc.).

Another field of application is the extraction of contents from plants, which is possible rapidly, efficiently and with high yields. Both the extraction time and the required extraction temperature are more cost-effective for a wide range of applications than with other extraction methods. The combination of classic extraction methods with the ultrasonic homogeniser has also proven successful in some cases. These processes can be employed in a laboratory or at production level with customised technology constellations. The ultrasonic homogeniser has also established itself excellently in the sample preparation for analysis for cosmetics, be it for particle size analysis, the homogenising of hydrophobic substances with high fat contents such as make-up, lipstick and mascara for analysis of the ingredients (e.g. via HPLC), or other analysis techniques.



5.2.5 Chemistry and pharma industry

The broad spectrum of products and processes in these two branches gives rise to the enormous number of possible applications for the procedures described above with the ultrasonic homogeniser, in laboratories and the sonoreactors at production level. On the one hand, there are the physical procedures of suspending and emulsifying for additives such as pigments or other supplementary components for lubricating oils, formula, etc. On the other hand, sonochemistry allows for the direct influencing of chemical reactions or polymerisations with regard to the yield, reaction speed, reaction control, etc. The overlaps between the pharma, chemical, phyto, cosmetics, life sciences and nanomaterials industries are now very high and the transitions are seamless.

As such, applications such as extraction, cell disruption and disagglomeration (for example for particular polymer structures) are also worth mentioning here. In order to avoid unnecessary repetition, these aspects are not all dealt with in detail here. For further information, please refer to the individual parts of chap. 4 for the basic application possibilities and other similar topics addressed in this section.

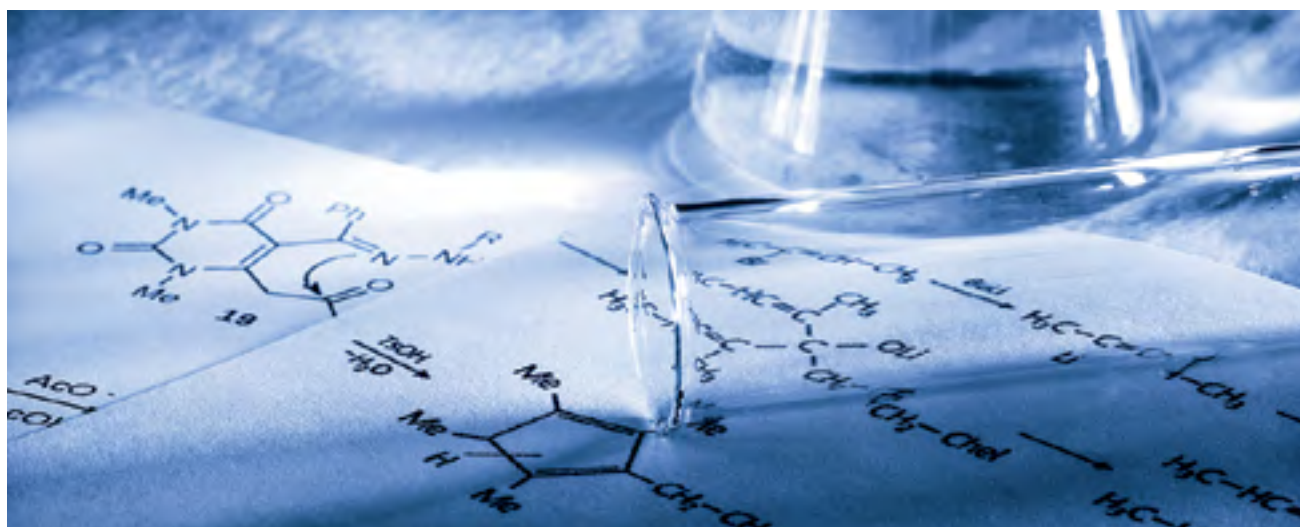

5.2.6 Ink & ink jets

The dispersion of ink pigments is an outstandingly introduced ultrasonic homogeniser application. As particle sizes down to the low nanometre range can be achieved, it is possible to produce particularly finely dispersed inks with resulting products that have correspondingly high-quality characteristics. It is possible to sonicate both water-based and solvent-based inks. An additional advantage is particularly reliable process control. It is also true that both process development at the laboratory level and up-scaling to production processes are possible with good results.



5.2.8 Construction industry

Ceramics and cement manufacturers, among others, employ ultrasonic homogenisers for a wide range of applications. The predispersing of slips and the suspension of substances such as aluminium oxide, silicon dioxide, etc., as well as sample preparation for particle size analysis are all examples of practical applications. Here too, the production process, such as the production of cement, can be influenced positively.



5.2.7 Paints & varnishes, surface coatings

Pigments, fillers and additives of all kinds can be effectively added to varnishes, paints and other surface coatings using ultrasound. Ultrasonic homogenisers are also used very successfully in the field of nanoparticles in laboratories and sonoreactors in production departments. For all tasks involving dispersing, emulsifying, suspending, disagglomeration, defoaming or degassing, ultrasound is a tried and tested means of conducting processes and optimising product features as described above. Ultrasound can also be employed outstandingly in the ever more desired changeover of solvent-based to water-based products and the reduction of VOCs, be it in product development in the laboratory or in the sonoreactor in production following upscaling. Disagglomeration or homogenising for sample preparation via an ultrasonic homogeniser can also be successfully employed in the field of analytics. There are also application possibilities in the field of synthesis, such as mini emulsion polymerisation to name but one example.



6 Detailed applications

A word in advance

The number of applications in a certain application field is not directly related to the suitability of the ultrasonic homogeniser for these applications. It can be largely attributed to the segments in which the use of the ultrasonic homogeniser has been established in practice for many years and those where the viability was only recently "discovered", often with particular success. The detail provided for each application is another criterion. Whereas individual description of the cell disruption for many different organisms appears practical, in other areas such as that of degassing, a general application is sufficient.

Ultimately, we can adopt as many varieties of the practice examples in this collection as are provided by cooperative users.

The collection of applications is expanding all the time. We are happy to receive any feedback concerning interesting applications.

The overview shows you which applications are already written down in practice reports. We will be delighted to send you the corresponding application notes on request (info@bandelin.com). If the application you are looking for is not there, please contact us. We will surely be able to provide you with some pointers.



HD 4200 with TS 113

6.1 Classification based on process

6.1.1 Dispersing, suspending

Number	Working area	Branch	Title
C-104	Dispersing/ suspending	Materials	Dispersing of carbon nanoparticles in processing oil
C-105	Dispersing/ suspending	Materials	Dispersing of ceramic raw materials and glass powder
C-107	Dispersing/ suspending	Pharma	Production of ultrafine pharmaceutical emulsions
C-108	Dispersing/ suspending	Polymers	Production of microcapsules with monomers
C-109	Dispersing/ suspending	Materials	Dispersing of solids such as aluminium oxide and silicone dioxide
C-202	Dispersing/ suspending	Materials	Suspending of multi-walled carbon nanotubes (MWCNTs), GFRPs and other hard-to-dissolve materials
C-203	Dispersing/ suspending	Materials	Sample preparation of ceramic suspensions for particle measurement – particle size analysis
C-207	Dispersing/ suspending	Polymers	Production of polymer particle suspensions
L-102	Dispersing/ suspending	Foodstuffs	Production of hop emulsions
C-301	Dispersing/ suspending	Materials	Producing ceramic slurries (Al ₂ O ₃ in water)
C-302	Sample preparation	Cosmetics	Sample preparation of cosmetics in organic and aqueous solvents
C-303	Dispersing/ suspending	Materials	Dispersing titanium dioxide in oil or water
C-304	Sample preparation	Miscellaneous	Dispersing of ettringite, aluminium and silicon dioxide for particle size analysis
C-305	Dispersing/ suspending	Materials	Dispersing of solids such as very fine titanium dioxide or aluminium oxide

6.1.2 Disagglomeration

Number	Working area	Branch	Title
B-208	Disagglomeration	Microbiology	Separation of yeasts for determination of the vital cell count
C-101	Disagglomeration/ particle size analysis	Materials	Disagglomeration of tungsten powder for subsequent particle size determination
C-102	Disagglomeration/ particle size analysis	Materials	Dispersing of fine metal powder (Al) for subsequent particle size determination
C-106	Disagglomeration/ particle size analysis	Water /waste-water	Disagglomeration of water sediment samples in preparation for particle size analysis
C-111T	Disagglomeration/ particle size analysis	Materials	Disagglomeration as sample preparation for particle size analysis – Tabular overview

C-204	Disagglomeration / particle size analysis	Materials	Sample preparation for the particle size measurement of catalyst dispersions
C-208	Disagglomeration / particle size analysis	Foodstuffs	Homogenising of solid food supplements in water for sample preparation for particle size analysis
C-304	Sample preparation	Miscellaneous	Dispersing of ettringite, aluminium and silicon dioxide for particle size analysis
C-305	Dispersing / suspending	Materials	Dispersing of solids such as very fine titanium dioxide or aluminium oxide
C-306	Disagglomeration	Materials	Desagglomeration of ceramic nanoparticles

6.1.3 Degassing, defoaming

see chap. 5.1.5

6.1.4 Extraction

Number	Working area	Branch	Title
C-201	Extraction	Soil	Extraction of exchangeable magnesium from soil
C-206	Extraction	Paints / varnishes	Extraction of oily ingredients from dried varnish
U-301	Extraction	Soil	Extraction of water-soluble ions from soils
U-303	Extraction / Sample preparation	Soil	Extraction/Homogenising of soil samples in liquids to analyse minerals like Mg, K, P, N

6.1.5 Sample preparation for analysis (except particle size analysis)

Number	Working area	Branch	Title
B-114	Sample preparation	Medicine	Homogenising of sperm for determination of quantity
B-212	Sample preparation	Molecular biology	Dissolving of peptides as sample preparation for analysis
C-110	Sample preparation	Water / wastewater	Sample preparation of wastewater samples
C-112T	Sample preparation	Miscellaneous	Sample preparation for analysis for soil and wastewater samples
C-205	Sample preparation	Cosmetics	Homogenising of cosmetics in solvents for sample preparation for analysis
C-210	Sample preparation	Water / wastewater	Sample preparation of wastewater containing particles, for TOC determination as per DIN EN 1484

L-101	Sample preparation	Foodstuffs	Fast and gentle isolation of fat for fatty acid determination in meat – Method improvement
L-103	Sample preparation	Foodstuffs	Identification of fatty acid distribution in bovine milk
L-201	Sample preparation	Foodstuffs	Sample preparation for determination of nitrate content in cheese (xylenol process)
L-202	Sample preparation	Foodstuffs	Sample preparation for potentiometric determination of chloride content in cheese
L-203	Sample preparation	Foodstuffs	Sample preparation for potentiometric determination of chloride content in cheese
L-204	Sample preparation	Foodstuffs	Sample preparation / homogenising of cheese and other foodstuffs and extraction of relevant analytes
U-203	Sample preparation	Water / wastewater	Sample preparation at a sewage plant
C-302	Sample preparation	Cosmetics	Sample preparation of cosmetics in organic and aqueous solvents
C-304	Sample preparation	Miscellaneous	Dispersing of ettringite, aluminium and silicon dioxide for particle size analysis
L-301	Sample preparation	Foodstuffs	Homogenising of frozen human milk and disruption of fat globules and disruption of fat globules
U-301	Extraction	Soil	Extraction of water-soluble ions from soils
U-302	Sample preparation	Waste	Preparation of waste samples
U-303	Extraction/ Sample preparation	Soil	Extraction/Homogenising of soil samples in liquids to analyse minerals like Mg, K, P, N

6.1.6 Sample preparation for particle size analysis

see chap. 6.1.2

6.1.7 Cell and tissue disruption

Cell disruption

Number	Working area	Branch	Title
B-101	Cell disruption	Molecular biology	Cell and tissue disruption, including in μ l-batches with indirect sonication in a beaker resonator
B-102	Cell disruption	Molecular biology	Cell disruption of yeast cells
B-108T	Cell disruption	Molecular biology	Cell disruption of Escherichia coli bacteria – tests with diverse parameters with the SONOPULS
B-109	Cell disruption	Molecular biology	Cell disruption of Pseudomonas thailandensis
B-110	Cell disruption	Molecular biology	Lysis and fragmentation of cell cultures via indirect sonication in the scope of cancer research
B-111	Cell disruption	Molecular biology	Procurement of proteins for the western blot technique, e.g., for evidence of HIV or other infections
B-112	Cell disruption	Molecular biology	Cell disruption of eukaryotic cells as preliminary step to protein isolation
B-113	Cell disruption	Molecular biology	Cell disruption of insect cells as preliminary step to protein isolation

B-115	Cell disruption	Molecular biology	Cell disruption of mammalian cells
B-117	Cell disruption	Molecular biology	Production of lysates from purchased cell cultures for antibody reactions
B-119T	Cell disruption	Molecular biology	Cell disruption of different organisms and cells – Tabular overview
B-201	Cell disruption	Molecular biology	Cell disruption of E. coli in volumes from µl to l
B-203	Cell disruption	Algae	Cell disruption of Haematococcus pluvialis microalgae for carotenoid analysis
B-205	Cell disruption	Molecular biology	Cell disruption of Escherichia coli for protein analysis
B-206	Cell disruption	Molecular biology/ Medicine	Cell disruption of human cells
B-207	Cell disruption	Algae	Cell disruption of microalgae and cyanobacteria
B-209	Cell disruption	Molecular biology	Production of cell lysates of eukaryotic cells in different volumes
B-211	Cell disruption	Molecular biology	Cell disruption for enzyme processing for E. coli or fungi cultures
B-302	Cell disruption	Molecular biology	Time-efficient disruption of human cells
B-305	Cell disruption	Materials	Disruption of Acetobacter xylinum
B-306	Cell disruption	Genetics	Disruption of Erythrocytes for the paternity test
B-307	Cell disruption	Biochemistry	Disruption of Candida albicans
B-308	Cell disruption	Microbiology	Disruption of Staphylococcus aureus
B-309	Cell disruption	Microbiology	Disruption of Streptococcus
B-310	Cell disruption	Microbiology	Disruption of Pseudomonas aeruginosa
B-311	Cell disruption	Microbiology	Disruption of Enterobacter for protein isolation

Tissue disruption

Number	Working area	Branch	Title
B-106	Tissue disruption	Tissue	Tissue disruptions, especially also for difficult tissues
B-107	Tissue disruption	Tissue	Tissue disruption of larger quantities, e.g., liver
B-116	Tissue disruption	Molecular biology	Production of protein lysates from tissue
B-118T	Tissue disruption	Tissue	Tissue disruption applications – Tabular overview
B-202	Tissue disruption	Toxicology	Tissue disruption –Homogenising of organs in forensic medicine
B-301	Tissue disruption	Molecular biology	Homogenising of mouse tissue for RNA isolation
B-304	Tissue disruption	Biochemistry	Disruption of dermal tissue

6.1.8 Miscellaneous

Number	Working area	Branch	Title
B-103	Miscellaneous	Medicine	Procurement of stroma-free haemolysate from EDTA blood for paternity testing
B-104	Miscellaneous	Molecular biology	Liposome production
B-105	Miscellaneous	Molecular biology	Replication of infectious prions – process acceleration via ultrasound
B-204	Miscellaneous	Molecular biology	Homogenising of peptide with Freund's adjuvant
B-210	DNA isolation	Molecular biology	Disruption of FFPE tissue for DNA isolation
C-103	Miscellaneous	Polymers	Degradation of cellulose using ultrasound
C-209	Miscellaneous	Materials	Phase transfer of iron oxide nanoparticles
B-303	Cell disruption	Biochemistry	Disruption of plant cells
B-305	Cell disruption	Materials	Disruption of Acetobacter xylinum
B-306	Cell disruption	Genetics	Disruption of Erythrocytes for the paternity test
B-307	Cell disruption	Biochemistry	Disruption of Candida albicans
B-308	Cell disruption	Microbiology	Disruption of Staphylococcus aureus
B-309	Cell disruption	Microbiology	Disruption of Streptococcus
B-310	Cell disruption	Microbiology	Disruption of Pseudomonas aeruginosa
B-311	Cell disruption	Microbiology	Disruption of Enterobacter for protein isolation
B-312	DNA-Fragmentation	Microbiology	Fragmentation of nucleic acid – synthetically degraded DNA

6.2 Classification by branches / working areas

6.2.1 Materials

Number	Working area	Branch	Title
C-101	Disagglomeration / particle size analysis	Materials	Disagglomeration of tungsten powder for subsequent particle size determination
C-102	Disagglomeration / particle size analysis	Materials	Dispersing of fine metal powder (Al) for subsequent particle size analysis
C-104	Dispersing/ suspending	Materials	Dispersing of carbon nanoparticles in process oils

C-105	Dispersing/ suspending	Materials	Dispersing of ceramic raw materials and glass powder
C-109	Dispersing/ suspending	Materials	Dispersing of solids such as aluminium oxide and silicone dioxide
C-111T	Disagglomeration/ particle size analysis	Materials	Disagglomeration as sample preparation for particle size analysis – Tabular overview
C-202	Dispersing/ suspending	Materials	Suspending of multi-walled carbon nanotubes (MWCNTs), GFRPs and other hard-to-dissolve materials
C-203	Dispersing/ suspending	Materials	Sample preparation of ceramic suspensions for particle measurement – particle size analysis
C-204	Disagglomeration/ particle size analysis	Materials	Sample preparation for the particle size measurement of catalyst dispersions
C-209	Miscellaneous	Materials	Phase transfer of iron oxide nanoparticles

6.2.2 Polymers / paints and varnishes

Number	Working area	Branch	Title
C-103	Miscellaneous	Polymers	Degradation of cellulose using ultrasound
C-108	Dispersing/ suspending	Polymers	Production of microcapsules with monomers
C-206	Extraction	Paints/ varnishes	Extraction of oily ingredients from dried varnish
C-207	Dispersing/ suspending	Polymers	Production of polymer particle suspensions

6.2.3 Environment

Number	Working area	Branch	Title
C-106	Disagglomeration/ particle size analysis	Water / waste- water	Disagglomeration of water sediment samples in preparation for particle size analysis
C-110	Sample preparation	Water / waste- water	Sample preparation of wastewater samples
C-201	Extraction	Soil	Extraction of exchangeable magnesium from soil
C-210	Sample preparation	Water / waste- water	Sample preparation of wastewater containing particles for TOC determination as per DIN EN 1484
U-203	Sample preparation	Water / waste- water	Sample preparation at a sewage plant

6.2.4 Life sciences / molecular biology

Number	Working area	Branch	Title
B-101	Cell disruption	Molecular biology	Cell and tissue disruption, including in μ l-batches with indirect sonication in a beaker resonator
B-102	Cell disruption	Molecular biology	Cell disruption of yeast cells
B-103	Miscellaneous	Medicine	Procurement of stroma-free haemolysate from EDTA blood for paternity testing
B-104	Miscellaneous	Molecular biology	Liposome production
B-105	Miscellaneous	Molecular biology	Replication of infectious prions – process acceleration via ultrasound
B-108T	Cell disruption	Molecular biology	Cell disruption of Escherichia coli bacteria – tests with diverse parameters with the SONOPULS
B-109	Cell disruption	Molecular biology	Cell disruption of Pseudomonas thailandensis
B-110	Cell disruption	Molecular biology	Lysis and fragmentation of cell cultures via indirect sonication in the scope of cancer research
B-111	Cell disruption	Molecular biology	Procurement of proteins for the western blot technique, e.g., for evidence of HIV or other infections
B-112	Cell disruption	Molecular biology	Cell disruption of eukaryotic cells as preliminary step to protein isolation
B-113	Cell disruption	Molecular biology	Cell disruption of insect cells as preliminary step to protein isolation
B-115	Cell disruption	Molecular biology	Cell disruption of mammalian cells
B-116	Tissue disruption	Molecular biology	Production of protein lysates from tissue
B-117	Cell disruption	Molecular biology	Production of lysates from purchased cell cultures for antibody reactions
B-119T	Cell disruption	Molecular biology	Cell disruption of different organisms and cells – Tabular overview
B-201	Cell disruption	Molecular biology	Cell disruption of E. coli in volumes from μ l to l
B-204	Miscellaneous	Molecular biology	Homogenising of peptide with Freund's adjuvant
B-205	Cell disruption	Molecular biology	Cell disruption of Escherichia coli for protein analysis
B-206	Cell disruption	Molecular biology/ medicine	Cell disruption of human cells
B-209	Cell disruption	Molecular biology	Production of cell lysates of eukaryotic cells in different volumes

B-210	DNA isolation	Molecular biology	Disruption of FFPE tissue for DNA isolation
B-211	Cell disruption	Molecular biology	Cell disruption for enzyme processing for E. coli or fungi cultures
B-212	Sample preparation	Molecular biology	Dissolving of peptides as sample preparation for analysis
B-301	Tissue disruption	Molecular biology	Homogenising of mouse tissue for RNA isolation
B-302	Cell disruption	Molecular biology	Time-efficient disruption of human cells
B-306	Cell disruption	Genetics	Disruption of Erythrocytes for the paternity test
B-308	Cell disruption	Microbiology	Disruption of Staphylococcus aureus
B-309	Cell disruption	Microbiology	Disruption of Streptococcus
B-310	Cell disruption	Microbiology	Disruption of Pseudomonas aeruginosa
B-311	Cell disruption	Microbiology	Disruption of Enterobacter for protein isolation
B-312	DNA-Fragmentation	Microbiology	Fragmentation of nucleic acid – synthetically degraded DNA

6.2.5 Medicine / toxicology / microbiology / algae

Number	Working area	Branch	Title
B-103	Miscellaneous	Medicine	Procurement of stroma-free haemolysate from EDTA blood for paternity testing
B-114	Sample preparation	Medicine	Homogenising of sperm for determination of quantity
B-202	Tissue disruption	Toxicology	Tissue disruption –homogenising of organs in forensic medicine
B-203	Cell disruption	Algae	Cell disruption of Haematococcus pluvialis microalgae for carotinoid analysis
B-207	Cell disruption	Algae	Cell disruption of microalgae and cyanobacteria
B-208	Disagglomeration	Microbiology	Separation of yeasts for determination of the vital cell count

6.2.6 Foodstuffs

Number	Working area	Branch	Title
C-208	Disagglomeration/ particle size analysis	Foodstuffs	Homogenising of solid food supplements in water for sample preparation for particle size analysis
L-101	Sample preparation	Foodstuffs	Fast and gentle isolation of fat for fatty acid determination in meat – Method improvement
L-102	Dispersing/ suspending	Foodstuffs	Production of hop emulsions
L-103	Sample preparation	Foodstuffs	Identification of fatty acid distribution in bovine milk
L-201	Sample preparation	Foodstuffs	Sample preparation for determination of nitrate content in cheese (xyleneol process)
L-202	Sample preparation	Foodstuffs	Sample preparation for potentiometric determination of chloride content in cheese
L-203	Sample preparation	Foodstuffs	Sample preparation for potentiometric determination of chloride content in cheese
L-204	Sample preparation	Foodstuffs	Sample preparation / homogenising of cheese and other foodstuffs and extraction of relevant analytes

6.2.7 Pharma / Cosmetics

Number	Working area	Branch	Title
C-107	Dispersing/ suspending	Pharma	Production of ultrafine pharmaceutical emulsions
C-205	Sample preparation	Cosmetics	Homogenising of cosmetics in solvents for sample preparation for analysis
C-302	Sample preparation	Cosmetics	Sample preparation of cosmetics in organic and aqueous solvents

6.3 Publications

You can find articles in which a wide variety (a few hundred) of our SONOPULS applications are explained, in select publications and on the internet using the keywords SONOPULS and BANDELIN.

Probenvorbereitung zur Bestimmung von Partikelgrößen – Desagglomeration mit Ultraschall-Homogenisatoren

Morten Schonert¹, Richard Winterhalter²,
Dr. rer. nat. Kirsten Siebertz³

-
- 1 Umicore AG & Co. KG, Automotive Catalyst, Hanau, Deutschland
 - 2 Bayerisches Landesamt für Gesundheit und Lebensmittelsicherheit, Chemikaliensicherheit und Toxikologie, Bayern, Deutschland,
 - 3 TDCLAB Dr. Siebertz GmbH, Nidderau, Deutschland

*Published in GIT Labor-Fachzeitschrift,
No. 01/2018, page 24 – 26*

Probenvorbereitung mit dem Ultraschall-Homogenisator – Einsatz im Analytiklabor nach Vergleich mit herkömmlicher Methode

(Einsatz des Ultraschall-Homogenisators für die Probenvorbereitung Lebensmittel (Käse))
Susanne Zellermann¹, Hagen Nusche²,
Dr. rer. nat. Kirsten Siebertz³

-
- 1 Landesamt für Landwirtschaft, Lebensmittelsicherheit und Fischerei MV, Standort Neubrandenburg, Deutschland
 - 2 Betriebsgesellschaft für Umwelt und Landwirtschaft, Nossen, Deutschland
 - 3 TDCLAB Dr. Siebertz GmbH, Nidderau, Deutschland

*Lecture VDLUFA Annual Congress 2016 in Rostock,
published in VDLUFA series of publications 73 (2016), 598*

Moderne Probenvorbereitung mit Ultraschall-Homogenisatoren – Praxistest für Lebensmittel und Gewebe

Dr. Cora Wunder¹, Susanne Zellermann²,
Dr. rer. nat. Kirsten Siebertz³

-
- 1 Inst. f. Rechtsmedizin, Universität Frankfurt, Deutschland
 - 2 Landesamt für Landwirtschaft, Lebensmittelsicherheit und Fischerei MV, Standort Neubrandenburg, Deutschland
 - 3 TDCLAB Dr. Siebertz GmbH, Nidderau, Deutschland

*Published in GIT Labor-Fachzeitschrift,
No. 11/2014, page 44 – 46*



Ultraschallanwendungen in Technik und Produktion

Jochen Bandelin¹, Dr. rer. nat. Kirsten Siebertz²

-
- 1 BANDELIN electronic GmbH & Co. KG, Berlin, Deutschland
 - 2 TDCLAB Dr. Siebertz GmbH, Nidderau, Deutschland

Published in LABO, No. 09/2016, page 40 – 42

Effiziente Probenvorbereitung für die Partikelanalyse

Morten Schonert¹, Richard Winterhalter²,
Dr. rer. nat. Kirsten Siebertz³

-
- 1 Umicore AG & Co. KG, Automotive Catalyst, Hanau, Deutschland
 - 2 Bayerisches Landesamt für Gesundheit und Lebensmittelsicherheit, Chemikaliensicherheit und Toxikologie, Bayern, Deutschland,
 - 3 TDCLAB Dr. Siebertz GmbH, Nidderau, Deutschland

Published in Chemie Extra, No. 06/2018

Preparing a Sample for Determining the Size of Particles

Morten Schonert¹, Richard Winterhalter²,
Dr. rer. nat. Kirsten Siebertz³

-
- 1 Umicore AG & Co. KG, Automotive Catalyst, Hanau, Deutschland
 - 2 Bayerisches Landesamt für Gesundheit und Lebensmittelsicherheit, Chemikaliensicherheit und Toxikologie, Bayern, Deutschland,
 - 3 TDCLAB Dr. Siebertz GmbH, Nidderau, Deutschland

Published in GIT Journal:

www.laboratory-journal.com/science/material-science/preparing-sample-determining-size-particles

November 30th, 2018

Viel Energie, wenig Aufwand

M. Hamacher¹, Dr. rer. nat. Kirsten Siebertz²

-
- 1 Chemisches und Veterinäruntersuchungsamt Westfalen (CVUA), Standort Hagen, Deutschland
 - 2 TDCLAB Dr. Siebertz GmbH, Nidderau, Deutschland

Published in LABO, No. 02/2019, page 43 – 44

7 FAQs

7.1 FAQs concerning practical application

Sample liquid splashes out of the vessel. What do I need to change? Possible solutions:

- Set a lower amplitude and test whether the result is still satisfactory
- Use conical vessels
- Increase the immersion depth

My sample fluid foams a lot. How can I prevent that?

- Increase the immersion depth
- Add glass beads
- Use a conical vessel
- Place wire on the surface of the sample

How deep should I insert the probe?

Normally min. 0.5 and max. 2 cm. Immersion that is too deep results in dampening of the probe that is too severe. This results in insufficient application of power to the sample.

In Eppendorf cups, as far as possible – ensure that the sample does not foam!

Can the probe touch the vessel during sonication?

No. This can result in damage to the probe and the vessel (melting, breakage).

Can I touch the probe with my hands during the sonication process?

No. This can result in bone damage.

I want to separate / disagglomerate cells without destroying them. What do I need to change?

Reduce the amplitude or use a probe with a larger diameter.

How is the power for SONOPULS ultrasonic homogenisers measured?

During the measurement of power, the sonication vessel should be used for the standard trials.

This vessel is filled with water. The temperature increase can be measured for a set period of time and the power density calculated from the volume, temperature increase and elapsed time, using the familiar formula.

This is done using the following formula¹:

$$P/V = \frac{c\Delta\theta}{\Delta t}$$

The following applies:

P/V	power density in water [W/cm ³]
P	power [W]
V	test water volume [cm ³]
c	specific heat capacity $\left[\frac{\text{J}}{\text{kg} \cdot \text{K}} \right]$
Δt	period of time between measurements of temperatures [s]
$\Delta\theta$	temperature difference between measurements of temperatures [K]

This method allows for documentation of the input of power in the test series. Further information can be requested from www.bandelin.com (power determination of SONOPULS ultrasonic homogenisers – 5169).

Can solvents be sonicated?

- Yes, but safe extraction of vapours must be guaranteed!
- Only small amounts!
- Observe the flashpoint; cooling may be required!

7.2 FAQs concerning devices, probes and safety aspects

What should be done if the probe displays mild pitting?

At depths of up to approx. 1 mm, the probes should be carefully polished manually in your facility. For further information, refer to the instructions for use.

Are probes available in different lengths?

No. The probes are always calibrated to the resonance frequency and dictated by the design. They vary in the millimetre range depending on the acoustic properties of the titanium cast used (batch).

Do I need to take anything into consideration when disposing of probes?

- Probes can be disposed of without any problems. They pose no hazards.
- They do not contain heavy metal and are thus environmentally friendly.
- Scrap dealers offer minor remuneration (titanium weighs very little but is valuable)

¹ Note: The formula is only adequate for small volumes

Can probes also be produced from another material?

Yes, but with the respective restrictions:

- **Quartz glass** – only low amplitudes are possible, as the material cannot withstand high amplitudes.
- **Ceramics** – permit higher amplitudes than quartz glass, but is liable to break.
- **Stainless steel** – very brittle. Breaks quickly and more likely to heat.
- **Aluminium** – too soft. A certain hardness is essential for prolonging cavitation erosion. Limited chemical resistance.

Is hearing protection necessary?

The ultrasonic homogeniser can be operated in a soundproof box, available for purchase from BANDELIN, please enquire for more information. Alternatively, hearing protection should be worn: capsule hearing protection with an HM value of 25 – 30 dB or similar ear plugs or coverings if capsule hearing protection is unsuitable for the respective application.

Safety aspects for use of ultrasonic homogenisers in solvent-based samples

see FAQs – Practical application

7.3 FAQs concerning standards and guidelines

Are ultrasonic homogenisers suitable as medical devices in accordance with Directive 98/79/EC concerning in vitro diagnostics?

Yes, SONOPULS-homogenisers and their special accessories are „In vitro diagnostic medical devices class 5“ (according to 98/79/EG).

Do ultrasonic homogenisers comply with RoHS guidelines?

The devices comply with RoHS guidelines.

8 A final word

We hope to have been able to provide you with a good overview of the options for the practical use of SONOPULS ultrasonic homogenisers. If you have any unanswered questions, please do not hesitate to contact us for a personal consultation. Feel free to send us your ideas for new contents in the application guide. We will also be delighted to adopt your customised methods as an application in our collection for community use.

Our individual applications can be requested in accordance with chap. 6 “Detailed applications” from: Marina.Herrmann@bandelin.com.

BANDELIN Ultrasound since 1955

Company portrait

We are a family-owned company located in Berlin and meanwhile run in the third generation, specialised in development, manufacturing and sales of ultrasonic devices, the corresponding accessories and application-specific cleaning agents and disinfectants.

A wide vertical range of manufacture, modern production lines and a motivated staff guarantee a high quality of the products. Our devices contribute to the success of our customers in the laboratory, medical, dental, pharmaceutical, industrial, craft as well as service.

As early as 1955, our company began developing and manufacturing high-performance ultrasonic devices. The constant expansion of the product range and a sharp rise in sales led to an expansion of the production area in 1985. In 1992, ultrasonic homogenisers and controllable, power-constant ultrasonic generators were introduced to the market.

The period from 1996 to 2004 was characterised by the development and production of innovative ultrasonic baths and immersible transducers as well as tube reactors for industrial applications.

In the following years, BANDELIN's product range was expanded by new laboratory ultrasonic devices. After the introduction of the ultrasonic bath for simultaneous cleaning and rinsing of MIC instruments, a further development was launched in 2016 for robotic instruments.

Today, the reputation of our brands SONOREX, SONOPULS, SONOMIC and TRISON stand for the high quality awareness of our employees and is equated in expert circles with ultrasound.

The most important product groups include:

- SONOREX – Ultrasonic baths and reactors
- SONOPULS – Ultrasonic homogenisers
- SONOMIC – Ultrasonic baths for rinsable MIC and standard instruments
- TRISON – Ultrasonic baths for robotic-, rinsable MIS and standard instruments
- TICKOPUR – Cleaning agents
- STAMMOPUR – Cleaning agents and disinfectants

We are innovation leaders in the development of ultrasonic devices and new areas of application. In the past we have registered 79 patents / utility models as well as 68 trade brands. Our participation in various committees in the development of new standards and guidelines serve to ensure the highest standards for ultrasonic applications.

As the only complete supplier of ultrasonic devices, accessories, disinfectants and cleaning agents with approvals and certifications according to ISO 9001 and ISO 13485, BANDELIN is the market leader.

Over one million units have already been delivered to our customers.

Standard and customised solutions

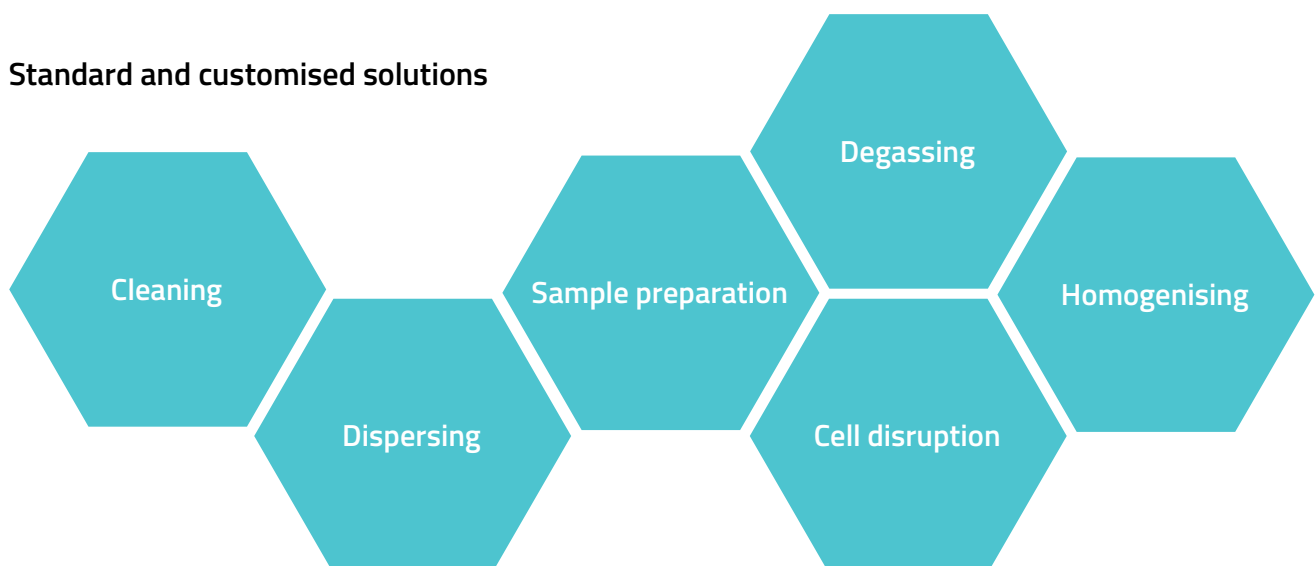

Made in Germany

BANDELIN electronic
GmbH & Co. KG
Heinrichstraße 3 – 4
12207 Berlin
DEUTSCHLAND
☎ +49 30 76880-0
☎ +49 30 7734699
✉ info@bandelin.com

Certified in accordance with
ISO 9001 and ISO 13485



We'll be happy to advise you in person!
Ask our experts.

+49 30 76880-0

www.bandelin.com

51022-002 GB/2020-11

Subject to technical alterations without notice.

Dimensions subject to production tolerances.

Illustrations exemplary, not true to scale.

Decoration products are not included in delivery.

The General Business Terms and Conditions apply.