



# VACUUM FOR LABORATORY

## CHEMISTRY DIAPHRAGM PUMPS

chemically resistant, durable and efficient



# CHEMISTRY DIAPHRAGM PUMPS

**chemically resistant, durable and efficient**

Typical applications for chemistry diaphragm pumps include evacuating chemically aggressive gases and vapors from equipment such as rotary evaporators, vacuum drying chambers, and many other laboratory applications. Chemistry diaphragm pumps from VACUUBRAND feature uncompromising chemistry designs. Their construction with fluoropolymers makes them very resistant to chemical vapors from inlet to exhaust. In this pump technology, pumping chambers are hermetically separated from the drive system. It is characterized by a high level of condensate compatibility. Two-, three- and four-stage pumps additionally have a gas ballast valve for all work with condensable vapors. Diaphragm pumps are oil-free, do not consume any water, and do not generate either wastewater or contaminated oil.

## Representative applications:



Drying



Rotary evaporation



Vacuum concentrators



Filtration



Local area vacuum network



Reactors & synthesis applications



Fore vacuum generation for turbomolecular pumps



## Technical highlights

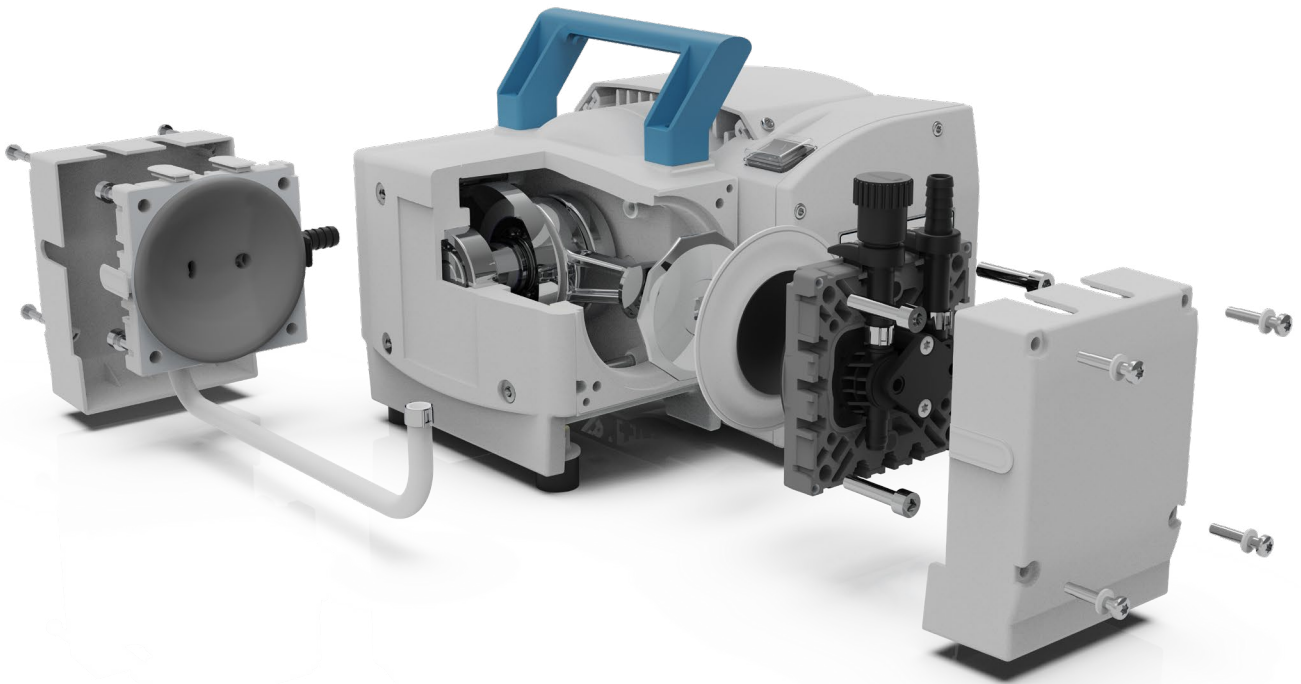

### chemically resistant

VACUUBRAND chemistry diaphragm pumps are uncompromisingly chemically resistant – even in the case of aggressive chemicals. All wetted parts are made of selected fluoroplastics. They are characterized by excellent chemical resistance and low material adhesion.

### durable

VACUUBRAND® chemistry diaphragm pumps offer unsurpassed long-time performance – even in rough conditions. Thanks to high-quality fluoropolymers, precise manufacturing processes, and 100% quality control, VACUUBRAND chemistry diaphragm pumps guarantee uncompromising chemical resistance, long service intervals, and longstanding reliability.

### efficient

Precise, efficient and quiet – VARIO® diaphragm pumps control the vacuum according to need via the motor speed. In combination with the VACUU-SELECT controller, they achieve the optimal conditions for reproducible processes. Parameters and process steps can be easily adjusted and saved using the touch display.

## Chemically resistant and durable

VACUUBRAND chemistry diaphragm pumps are uncompromisingly chemically resistant – even in the case of aggressive chemicals. All wetted parts are made of selected fluoroplastics. They are characterized by excellent chemical resistance and low material adhesion.

VACUUBRAND chemistry diaphragm pumps stand for unrivaled years of reliability, even in harsh chemistry applications. To achieve this, we use a special diaphragm technology and carefully selected materials.

The most heavily stressed components are produced in a complex, multi-stage manufacturing process. In this process, a stable metal core is coated with chemically resistant fluoroplastics.

As the result of multi-year performance tests, we have determined a typical diaphragm service life of 15,000 operating hours for our pumps. Thanks to the maintenance friendly design, diaphragms and valves can be easily changed. VACUUBRAND diaphragm pumps therefore run for many years with high reliability and require only minimal maintenance.

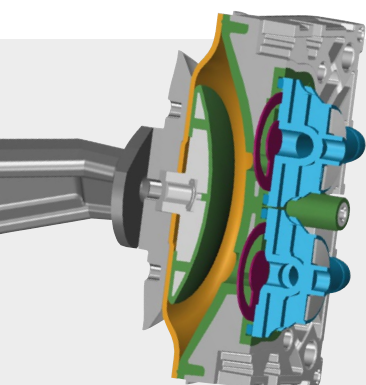

Pump chamber of a chemistry diaphragm pump

### Chemistry compatibility of VACUUBRAND chemistry diaphragm pumps

**PTFE:** Polytetrafluoroethylene

**ETFE:** Ethylene tetrafluoroethylene

**ECTFE:** Ethylene chlorotrifluoroethylene

**FFKM:** Perfluoro elastomer

**++** excellent chemical resistance

**+** good to limited chemical resistance

**-** poor chemical resistance

**\*** for some solvents '+'

	PTFE	ETFE/ ECTFE	FFKM
<b>Acid amides</b> Dimethylformamide (DMF), Acetamide, Formamide	++	++	++
<b>Acids, dilute or weak</b> Acetic acid, Carbonic acid, Butyric acid	++	++	++
<b>Acids, strong or concentrated</b> Hydrochloric acid, Sulfuric acid, Nitric acid, Trifluoroacetic acid (TFA)	++	++	++
<b>Alcohols, aliphatic</b> Methanol, Ethanol, Butanol	++	++	++
<b>Aldehydes</b> Formaldehyde, Ethanal, Hexanal	++	++	++
<b>Amines</b> N-Methyl-2-pyrrolidone (NMP), Triethylamine	++	++	+
<b>Bases</b> Sodium hydroxide, Potassium hydroxide, Ammonia	++	++	++
<b>Esters</b> Ethyl acetate, Butyl formate, Amyl butyrate	++	++	++
<b>Ethers</b> Diethyl ether, Tetrahydrofurane, Dioxane	++	++	++
<b>Hydrocarbons, aliphatic</b> Pentane, Hexane, Heptane	++	++	++
<b>Hydrocarbons, aromatic</b> Benzene, Toluene, Xylene	++	++	++
<b>Hydrocarbons, halogenated</b> Methyl chloride, Chloroform, Ethylene chloride	++	++	++
<b>Ketones</b> Acetone, Cyclohexanone	++	+++*	++
<b>Oxidizing acids, oxidizing agents</b> Ozone, Hydrogen peroxide, Chlorine	++	+	++
<b>Sulfoxides</b> Dimethyl sulfoxide (DMSO)	++	++	++

The data are based on information from various literature. VACUUBRAND does not warrant the accuracy of these data. Due to the variety of possible influencing factors, they can serve only as a guide. No legal claims may be derived from user reliance on these data.

## Efficient

### VACUU-SELECT

VACUU-SELECT makes your tasks simple, easy, and efficient. Choose your application from a set of pre-defined applications or create your own routine in next to no time. Everything is right at your fingertips with the intuitive VACUU-SELECT user interface.

- Intuitive touch-screen control
- Application editor for individual processes
- Pre-defined vacuum processes
- Favourites menu for frequently used processes
- Fully automatic evaporations at the touch of a button



### VARIO

VARIO-pumps provide pinpoint vacuum control by adjusting the motor speed. This guarantees optimal process times and reproducible results. VARIO-pumps run on demand for maximum energy efficiency, increased service intervals, and whisper quiet operation.

In Automated Evaporation mode, the VACUU-SELECT controller automatically detects solvent vapor pressures. With continuous optimization of the vacuum level based on real-time process conditions, there is no need to actively monitor your process – no more babysitting is required.

- Reliably maintains control for you – no more babysitting
- Makes manual adjustments and programming a thing of the past
- Minimizes foaming and sample loss
- Whisper quiet operation
- Drastically reduced power consumption
- Decreased service demand
- Minimizes process times, saving as much as 30% compared to other control methods
- Generates reproducible results



## Variants



### Basic model

Oil-free, chemically resistant diaphragm pumps for pumping aggressive gases and vapors.



### Variants without vacuum control

Inlet separator (AK) catches liquid and physical material (condensate or particles) from the suction flow at the inlet of the pump. The pressure-side emission condenser (EK) enables nearly 100% solvent recovery.



### Variants with 2-point vacuum valve control

Using the VACUU-SELECT controller, you control the vacuum and process steps intuitively using the touch display. The 2-point vacuum valve control is carried out by automatically opening and closing a suction line valve.



### Variants with VARIO control

Using the VACUU-SELECT controller, you control the vacuum and process steps intuitively using the touch display. VARIO pumps control the vacuum by adjusting the motor speed. It offers the utmost precision, maximum efficiency and is especially quiet.



Find the right vacuum pump with the Vacuum Pump Selection Guide!  
[www.vacuubrand.com/vpsg](http://www.vacuubrand.com/vpsg)

## Control technology

VACUU·SELECT supports two vacuum control procedures. Classic 2-point control uses a solenoid valve with the VACUU·SELECT controller. Advanced VARIO control achieves unparalleled precision with motor speed control.

### Classic 2-point vacuum valve control

- ✓ Control by opening and closing a vacuum valve
- ✓ Automatic vapor pressure detection
- ✓ Pump always runs at full speed
- ✓ Vacuum is maintained between the two valve switching points within the defined hysteresis range

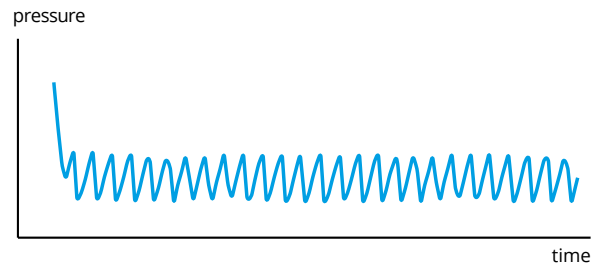

### Pinpoint VARIO control via motor speed control

- ✓ Control via motor speed of the pump
- ✓ Pump speed adjusts in realtime
  - Drastically reduced power consumption
  - Whisper quiet operation
  - Decreased service demand
- ✓ Pinpoint vacuum
  - Minimizes process times, saving as much as 30% compared to other control methods
- ✓ Fully automatic evaporations at the touch of a button thanks to proven and reliable boiling pressure detection and continuous tracking through out the entire process duration
  - Minimizes foaming and sample loss
  - Makes manual adjustments and programming a thing of the past



Convert into various common units!  
[www.vacuubrand.com/calculate](http://www.vacuubrand.com/calculate)

## Basic model



- ✓ Outstanding chemical resistance and superior vapor tolerance
- ✓ Excellent pumping speed, even close to the ultimate vacuum
- ✓ Good ultimate vacuum even with opened gas ballast valve
- ✓ Extra quiet, low-vibration operation
- ✓ High long-term diaphragm lifetime, maintenance-free operation

## Description

Chemistry-design diaphragm pumps are an excellent solution for continuous, oil-free pumping of aggressive gases and vapors and meet the highest demands. The innovative VACUUBRAND design combines high pumping speed with a very good ultimate vacuum. All major parts in contact with pumped media are made of chemically resistant fluoroplastics. Well-proven PTFE sandwich diaphragms increase reliability and extend operating life.

## Products



**ME 1C**  
100 mbar | 0.7 m<sup>3</sup>/h

**ME 2C NT**  
70 mbar | 2.1 m<sup>3</sup>/h

**ME 4C NT**  
70 mbar | 3.9 m<sup>3</sup>/h

**ME 8C NT**  
70 mbar | 7.1 m<sup>3</sup>/h

**ME 16C NT**  
70 mbar | 16.3 m<sup>3</sup>/h



**MZ 1C**  
12 mbar | 0.75 m<sup>3</sup>/h

**MZ 2C NT**  
7 mbar | 2.0 m<sup>3</sup>/h

**PC 101 NT**  
7 mbar | 2.0 m<sup>3</sup>/h



**MD 1C**  
2 mbar | 1.3 m<sup>3</sup>/h

**MD 4C NT**  
1.5 mbar | 3.4 m<sup>3</sup>/h

**MD 12C NT**  
2 mbar | 12.0 m<sup>3</sup>/h

**PC 3001 basic**  
2 mbar | 2.0 m<sup>3</sup>/h

**PC 201 NT**  
1.5 mbar | 3.4 m<sup>3</sup>/h



**MV 10C NT**  
0.9 mbar | 9.5 m<sup>3</sup>/h



## Variants without vacuum control



- ✓ All advantages of the basic model
- ✓ Versions with AK: Protection of the pump from particles and liquid droplets
- ✓ Versions with EK: excellent environmental credentials thanks to efficient solvent recovery
- ✓ Synchro versions enable two applications to be operated at the same time, with individual control options. The integrated, check valves prevent mutual interference and cross contamination

### Description

These vacuum pumps have a very wide range of application in evacuating, evaporating and pumping gases in chemical, biological and pharmaceutical laboratories. The separator at the inlet (AK) is made of glass with protective coating and retains particles and liquid droplets. The compact emission condenser (EK) on the exhaust side is particularly effective. It enables almost 100% solvent recovery for economical reuse and active protection of the environment.

Synchro-variants enable two independent vacuum applications by a single pump. Each vacuum port is designed with a flow-control valve for easy adjustment of the effective volume flow rate.

### Products



**ME 4C NT +2AK**  
70 mbar | 3.9 m<sup>3</sup>/h

**ME 8C NT +2AK**  
70 mbar | 7.1 m<sup>3</sup>/h

**ME 16C NT +EK**  
70 mbar | 16.3 m<sup>3</sup>/h



**MZ 2C NT +2AK**  
7 mbar | 2.0 m<sup>3</sup>/h

**MZ 2C NT +AK+EK**  
7 mbar | 2.0 m<sup>3</sup>/h

**MZ 2C NT +AK SYNCHRO+EK**  
7 mbar | 2.0 m<sup>3</sup>/h

**MZ 2C NT +AK+M+D**  
7 mbar | 2.0 m<sup>3</sup>/h



**MD 1C +AK+EK**  
2 mbar | 1.3 m<sup>3</sup>/h

**MD 4C NT +2AK**  
1.5 mbar | 3.4 m<sup>3</sup>/h

**MD 4C NT +AK+EK**  
1.5 mbar | 3.4 m<sup>3</sup>/h

**MD 4C NT +AK SYNCHRO+EK**  
1.5 mbar | 3.4 m<sup>3</sup>/h

**MD 12C NT +EK**  
2 mbar | 12 m<sup>3</sup>/h

**MD 12C NT +AK+EK**  
2 mbar | 12 m<sup>3</sup>/h



**MV 10C NT +EK**  
0.9 mbar | 9.5 m<sup>3</sup>/h

## Variants with 2-point vacuum valve control



- ✓ All advantages of the basic model or variants without vacuum control
- ✓ Vacuum controller VACUU·SELECT with intuitive user interface
- ✓ Control by opening and closing a vacuum valve
- ✓ Controller detects solvent boiling then holds the pressure level
- ✓ PC 520 select and PC 620 select: Pumping units can be configured to run one or two independent processes at the same time with one VACUU·SELECT

### Description

These chemistry pumping units use chemical resistant solenoid valves to maintain process control. Once the first boiling point is detected by the controller, it maintains the pressure at this level.

With the pumping stations PC 520 select and PC 620 select it is even possible to control two different vacuum processes in parallel with just one VACUU·SELECT. In this case, a separate solenoid valve and vacuum sensor are installed for each process.

The pumping stations PC 511 select and PC 611 select each have a combination of one electronic control and one manual vacuum control connection, which also enables parallel control of two different vacuum processes.

All pumping stations are also equipped with a suction-side inlet separator (AK) and a exhaust-side emission condenser (EK).

### Products



**PC 510 select**  
7 mbar | 2.0 m<sup>3</sup>/h

**PC 511 select**  
7 mbar | 2.0 m<sup>3</sup>/h

**PC 520 select**  
7 mbar | 2.0 m<sup>3</sup>/h

**PC 610 select**  
1.5 mbar | 3.4 m<sup>3</sup>/h

**PC 611 select**  
1.5 mbar | 3.4 m<sup>3</sup>/h

**PC 620 select**  
1.5 mbar | 3.4 m<sup>3</sup>/h

## Variants with VARIO control



- ✓ All advantages of the basic model or variants without vacuum control
- ✓ Vacuum controller VACUU·SELECT with intuitive user interface
- ✓ Unprecedented long-term performance and uncompromising chemical resistance
- ✓ Fully automatic evaporation at the touch of a button thanks to innovative boiling pressure detection and continuous tracking
- ✓ Whisper quiet operation with significantly reduced speed
- ✓ Minimal operating costs due to reduced power consumption, oil-free and long service intervals
- ✓ Ideal solution for chemical processes that require precise vacuum

### Description

VARIO-pumps and pumping units control the vacuum precisely via motor speed. The combination of speed controlled VARIO chemistry diaphragm pumps and the new VACUU·SELECT vacuum controller makes the VARIO select chemistry pumps the ideal solution for chemical processes that require precise vacuum. The pumping units are also equipped with a suction-side separator (AK) and a exhaust-side emission condenser (EK).

### Products



**ME 16C VARIO select**  
70 mbar | 20.0 m<sup>3</sup>/h

**PC 3016 VARIO select**  
70 mbar | 20.0 m<sup>3</sup>/h



**MZ 2C VARIO select**  
7 mbar | 2.8 m<sup>3</sup>/h

**PC 3002 VARIO select**  
7 mbar | 2.8 m<sup>3</sup>/h



**PC 3001 VARIO select**  
2.0 mbar | 2.0 m<sup>3</sup>/h

**MD 4C VARIO select**  
1.5 mbar | 4.6 m<sup>3</sup>/h

**PC 3004 VARIO select**  
1.5 mbar | 4.6 m<sup>3</sup>/h

**MD 12C VARIO select**  
1.5 mbar | 15.0 m<sup>3</sup>/h

**PC 3012 VARIO select**  
1.5 mbar | 15.0 m<sup>3</sup>/h



**MV 10C VARIO select**  
0.6 mbar | 13.0 m<sup>3</sup>/h

**PC 3010 VARIO select**  
0.6 mbar | 13.0 m<sup>3</sup>/h

**PC 3003 VARIO select**  
0.6 mbar | 2.8 m<sup>3</sup>/h

VACUUBRAND GMBH + CO KG  
Alfred-Zippe-Straße 4  
97877 Wertheim, Deutschland

T +49 9342 808-5550  
F +49 9342 808-5555

[info@vacuubrand.com](mailto:info@vacuubrand.com)  
[www.vacuubrand.com](http://www.vacuubrand.com)